

ADRIAN PERRIG & TORSTEN HOEFLER

Networks and Operating Systems (252-0062-00)

Chapter 8: Filesystem Implementation

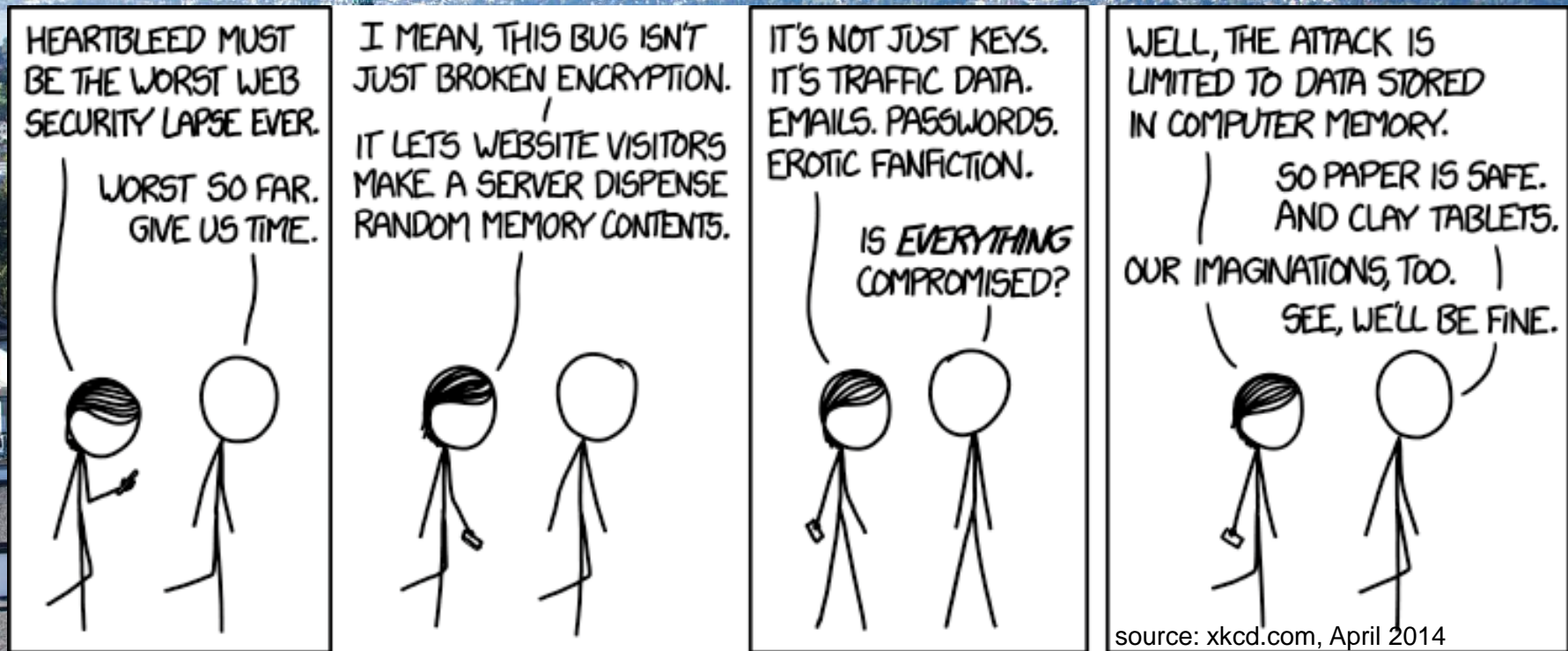

Nearly made it into pop-culture ☺

♥ Heartbeat – Normal usage

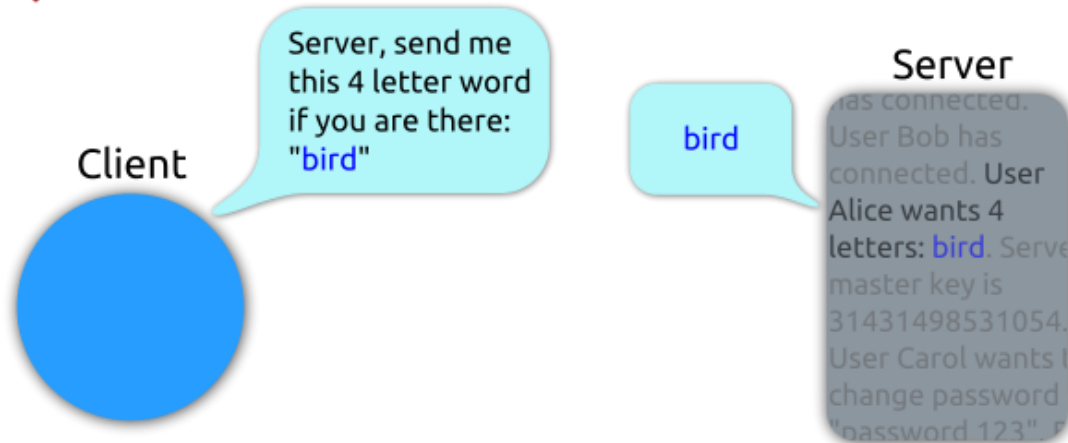

♥ Heartbeat – Malicious usage

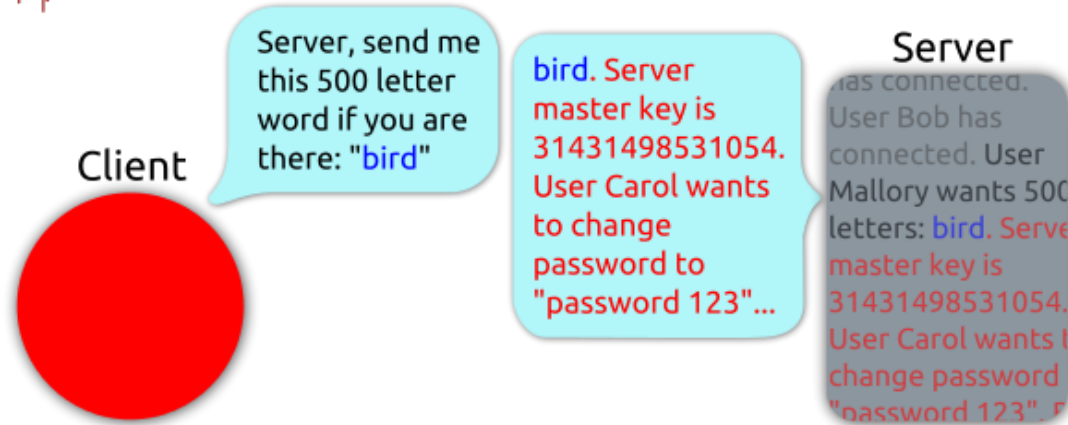

Next Thursday (March 24th)

- No lecture!



Our Small Quiz

- **True or false (raise hand)**
 - A file name identifies a string of data on a storage device
 - The file size is part of the file's metadata
 - Names provide a means of abstraction through indirection
 - Names are always assigned at object creation time
 - A context is implicit to a name
 - A context is implicit to an object
 - Name resolve may be specific to a context
 - Each file has exactly one name
 - The call “unlink file” always removes the contents of “file”
 - A fully qualified domain name is resolved recursively starting from the left
 - A full (absolute) path identifies a unique (1:1) file (piece of data)
 - A full (absolute) path identifies a unique name
 - Stable bindings can be changed with bind()
 - Each name identifies exactly one object in a single context

Access Control

Protection

- **File owner/creator should be able to control:**
 - what can be done
 - by whom

- **Types of access**
 - Read
 - Write
 - Execute
 - Append
 - Delete
 - List

Access control matrix

For a single file or directory:

Principals

	A	B	C	D	E	F	G	H	J	...
Read	<input checked="" type="checkbox"/>	<input checked="" type="checkbox"/>	<input checked="" type="checkbox"/>			<input checked="" type="checkbox"/>	<input checked="" type="checkbox"/>			
Write	<input checked="" type="checkbox"/>	<input checked="" type="checkbox"/>		<input checked="" type="checkbox"/>			<input checked="" type="checkbox"/>			
Append	<input checked="" type="checkbox"/>				<input checked="" type="checkbox"/>					
Execute	<input checked="" type="checkbox"/>	<input checked="" type="checkbox"/>	<input checked="" type="checkbox"/>	<input checked="" type="checkbox"/>						
Delete	<input checked="" type="checkbox"/>									
List	<input checked="" type="checkbox"/>				<input checked="" type="checkbox"/>					
...										

Problem: how to scalably represent this matrix?

Row-wise: ACLs

- **Access Control Lists**
 - For each right, list the principals
 - Store with the file
- **Good:**
 - Easy to change rights quickly
 - Scales to large numbers of files
- **Bad:**
 - Doesn't scale to large numbers of principals

Column-wise: Capabilities

- **Each principal with a right on a file holds a *capability* for that right**
 - Stored with principal, not object (file)
 - Cannot be forged or (sometimes) copied
- **Good:**
 - Very flexible, highly scalable in principals
 - Access control resources charged to principal
- **Bad:**
 - Revocation: hard to change access rights (need to keep track of who has what capabilities)

POSIX (Unix) Access Control

- **Simplifies ACLs: each file identifies 3 principals:**
 - Owner (a single user)
 - Group (a collection of users, defined elsewhere)
 - The World (everyone)
- **For each principal, file defines 3 rights:**
 - Read (or traverse, if a directory)
 - Write (or create a file, if a directory)
 - Execute (or list, if a directory)

Example

```
drwx--x--x  9 htor htor    4096 May  9 13:14 pagai
htor@lenny ~ > ls -l projekte/llvm/llvm-svn
total 860
drwx--x--x  3 htor htor    4096 Jan 29 15:58 autoconf
drwx--x--x  4 htor htor    4096 Dec 25 13:20 bindings
drwx--x--x  4 htor htor    4096 Jan 29 15:57 cmake
-rw-----  1 htor htor   16401 Dec 25 13:20 CMakeLists.txt
-rw-----  1 htor htor    2782 Jan 29 15:57 CODE_OWNERS.TXT
-rwx-----  1 htor htor  658352 Jan 29 15:57 configure
-rw-----  1 htor htor   10048 Dec 25 13:20 CREDITS.TXT
drwxr-xr-x 11 htor htor    4096 Apr  4 11:13 Debug
drwx--x--x 10 htor htor    4096 Jan 29 15:57 docs
drwx--x--x 10 htor htor    4096 Dec 25 13:20 examples
drwx--x--x  4 htor htor    4096 Dec 25 13:20 include
drwx--x--x 18 htor htor    4096 Jan 29 15:58 lib
-rw-----  1 htor htor   3254 Jan 29 15:57 LICENSE.TXT
-rw-----  1 htor htor    752 Dec 25 13:20 LLVMBuild.txt
-rw-----  1 htor htor   1865 Dec 25 13:20 llvm.spec.in
-rw-----  1 htor htor   8618 Jan 29 15:58 Makefile
-rw-----  1 htor htor   2599 Dec 25 13:20 Makefile.common
-rw-----  1 htor htor  12068 Jan 29 15:57 Makefile.config.in
-rw-----  1 htor htor  79586 Jan 29 15:57 Makefile.rules
drwx--x--x  4 htor htor    4096 Dec 25 13:21 projects
-rw-----  1 htor htor    687 Jan 29 15:58 README.txt
drwx--x--x  3 htor htor    4096 Dec 25 13:20 runtime
drwx--x--x 27 htor htor    4096 Jan 29 15:57 test
drwx--x--x 35 htor htor    4096 Dec 25 13:21 tools
drwx--x--x 11 htor htor    4096 Jan 29 15:57 unittests
drwx--x--x 32 htor htor    4096 Jan 29 15:57 utils
```

Full ACLs

- **POSIX now supports full ACLs**
 - Rarely used, interestingly
 - setfacl, getfacl, ...
- **Windows has very powerful ACL support**
 - Arbitrary groups as principals
 - Modification rights
 - Delegation rights

File Types

Is a directory a file?

- **Yes...**
 - Allocated just like a file on disk
 - Has entries in other directories like a file
- **...and no...**
 - Users can't be allowed to read/write to it
 - Corrupt file system data structures*
 - Bypass security mechanisms*
 - File system provides special interface
 - opendir, closedir, readdir, seekdir, telldir, etc.*

Directory implementation

- **Linear list** of (file name, block pointer) pairs
 - Simple to program
 - Lookup is slow for lots of files (linear scan)
- **Hash Table** – linear list with closed hashing.
 - Fast name lookup
 - **Collisions**
 - Fixed size
- **B-Tree** – name index, leaves are block pointers
 - Increasingly common
 - Complex to maintain, but scales well

File types

- **Other file types treated “specially” by the OS**
- **Simple, common cases:**
 - Executable files
 - Directories, symbolic links, other file system data
- **Some distinguish between text and binary**
- **Some have many types**
 - “Document” or “media” types
 - Used to select default applications, editors, etc.

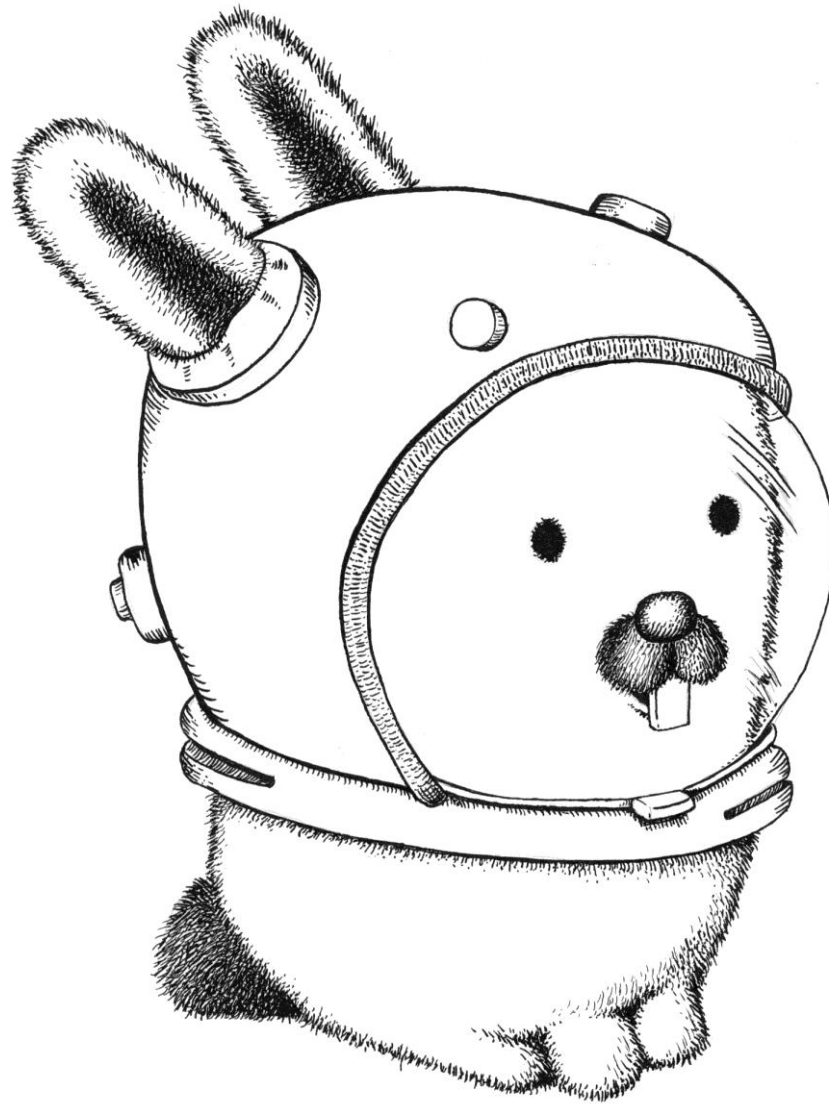

Unix devices and other file types

- **Unix also uses the file namespace for**
 - Naming I/O devices (/dev)
 - Named pipes (FIFOs)
 - Unix domain sockets
- **More recently:**
 - Process control (/proc)
 - OS configuration and status (/proc, /sys)
- **Plan 9 from Bell Labs**
 - Evolution of Unix: almost *everything* is a file

Executable files

- **Most OSes recognize binary executables**
 - Sometimes with a “magic number”
 - Will load, dynamically link, and execute in a process
- **Other files are sometimes recognized**
 - E.g. “#!” script files in Unix
“#!/usr/bin/python”

File system operations

File operations:

- **Create and variants**
 - Unix: `mknod`, `mkfifo`, `ln -s`, ...
- **Change access control**
 - Unix: `chmod`, `chgrp`, `chown`, `setfacl`, ...
- **Read metadata**
 - Unix: `stat`, `fstat`, ...
- **Open**
 - Operation: *file* → *open file handle*

“Files” vs. “Open Files”

- **Typical operations on files:**
 - Rename, stat, create, delete, etc.
 - **Open**
- **Open creates an “open file handle”**
 - Different class of object
 - Allows reading and writing of file data

Open File Interface

Kinds of files

1. Byte sequence

- The one you're probably familiar with

2. Record sequence

- Fixed (at creation time) records
- Mainframes or minicomputer OSes of the 70s/80s

3. Key-based, tree structured

- E.g. IBM Indexed Sequential Access Method (ISAM)
- Mainframe feature, now superseded by databases
- In other words, moved into libraries

Byte-sequence files

- **File is a vector of bytes**
 - Can be appended to
 - Can be truncated
 - Can be updated in place
 - Typically no “insert”
- **Accessed as:**
 - Sequential files (rare these days)
 - Random access

Random access

- **Support read, write, seek, and tell**
 - State: current position in file
 - **Seek** absolute or relative to current position.
 - **Tell** returns current index
- **Index units:**
 - For byte sequence files, offset in bytes

Record-sequence files

- **File is now a vector of fixed-size records**
 - Can be appended to
 - Can be truncated
 - Can be updated in place
 - Typically no “insert”
- **Record size (and perhaps format) fixed at creation time**
 - Read/write/seek operations take records and record offsets instead of byte addresses

Compare with
databases!

Memory-mapped files

- **Basic idea: use VM system to cache files**
 - Map file content into virtual address space
 - Set the backing store of region to file
 - Can now access the file using load/store
- **When memory is paged out**
 - Updates go back to file instead of swap space

On-disk Data Structures

Disk addressing

- **Disks have tracks, sectors, spindles, etc.**
 - And bad sector maps!
- **More convenient to use *logical block addresses***
 - Treat disk as compact linear array of usable blocks
 - Block size typically 512 bytes
 - Ignore geometry except for performance (later!)
- **Also abstracts other block storage devices**
 - Flash drives (load-leveling, etc.)
 - Storage-area Networks (SANs)
 - Virtual disks (RAM, RAID, etc.)



Implementation aspects

- **Directories and indexes**
 - Where on the disk is the data for each file?
- **Index granularity**
 - What is the unit of allocation for files?
- **Free space maps**
 - How to allocate more sectors on the disk?
- **Locality optimizations**
 - How to make it go fast in the common case

File system implementations

	FAT	FFS	NTFS	ZFS
Index structure	Linked list	Fixed, asymmetric tree	Dynamic tree	Dynamic COW tree
Index granularity	Block	Block	Extent	Block
Free space management	FAT array	Fixed bitmap	Bitmap in file	Log-structured space map
Locality heuristics	Defragmentation	Block groups, Reserve space	Best fit, Defragmentation	Write anywhere, Block groups



See book
for details

FAT-32

FAT background

- Very old – dates back to 1970s!
- No access control
- Very little metadata
- Limited volume size
- No support for hard links
- **BUT still extensively used** ☹
 - Flash devices, cameras, phones

- **Legend:** During the development of Windows 3.0, it was customary to have regular meetings with Bill Gates to brief him on the status of the project. At one of the reviews, the topic was performance, and Bill complained, ***"You guys are spending all this time with your segment tuning tinkering. I could teach a twelve-year-old to segment-tune. I want to see some real optimization, not this segment tuning nonsense. I wrote FAT on an airplane, for heaven's sake."***



Bundesarchiv, B 146 Bild-F077009-0042
Foto: Retnema, Digitized by April 1993

FAT file system

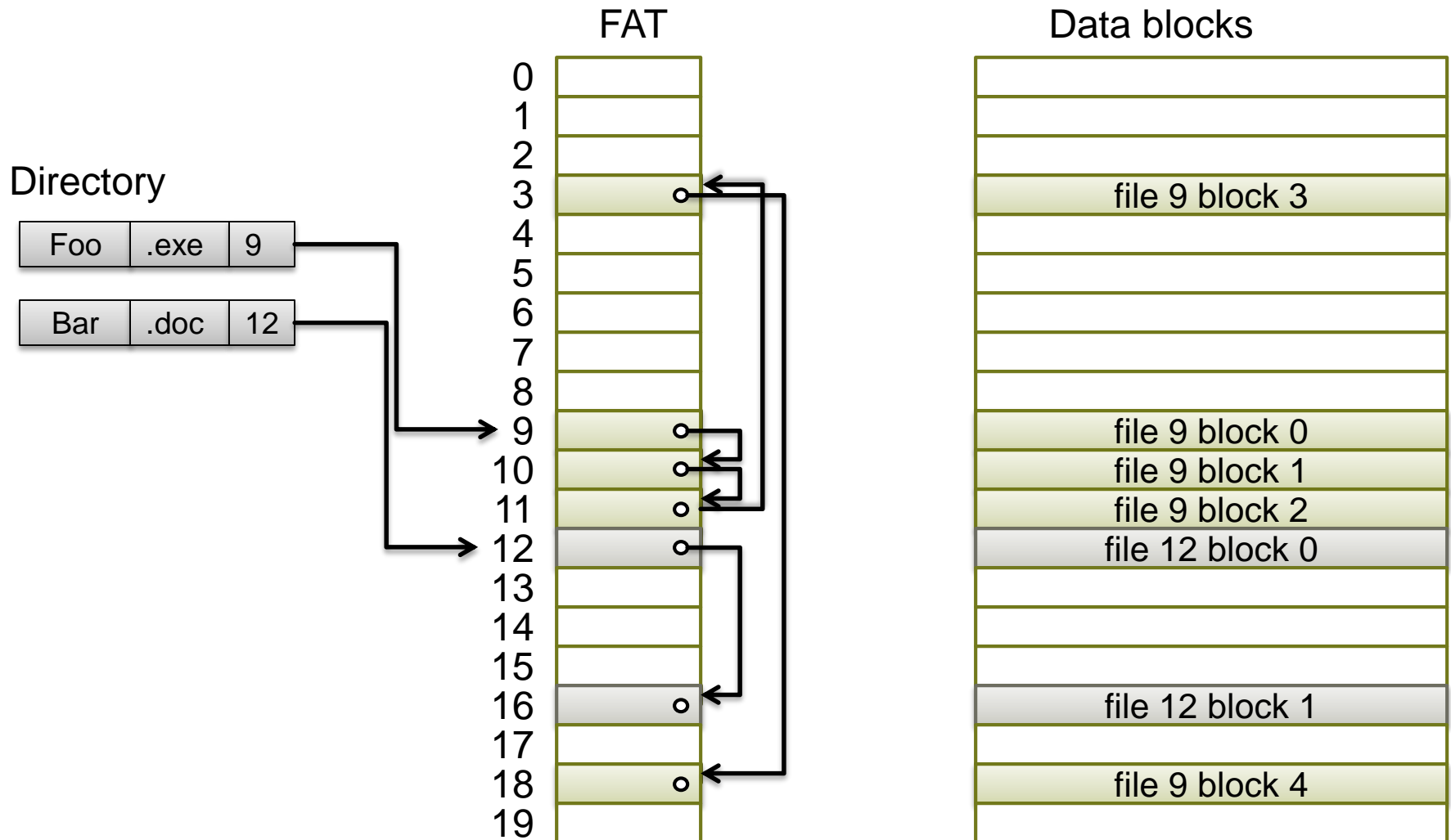

FAT file system

Free space:
Linear search
through FAT

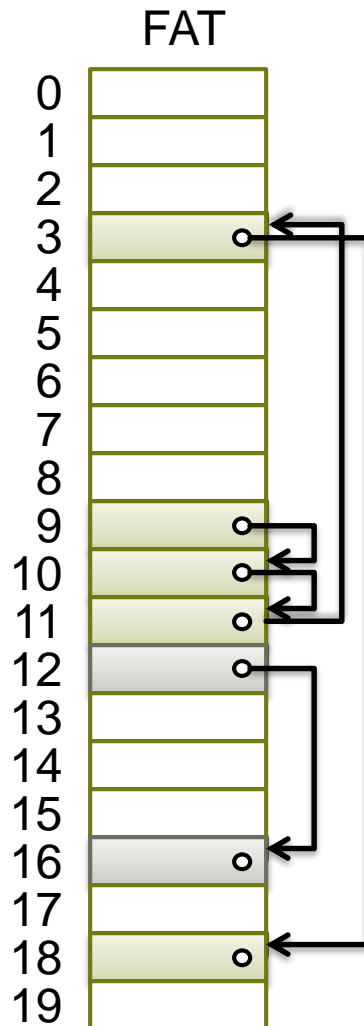

Data blocks

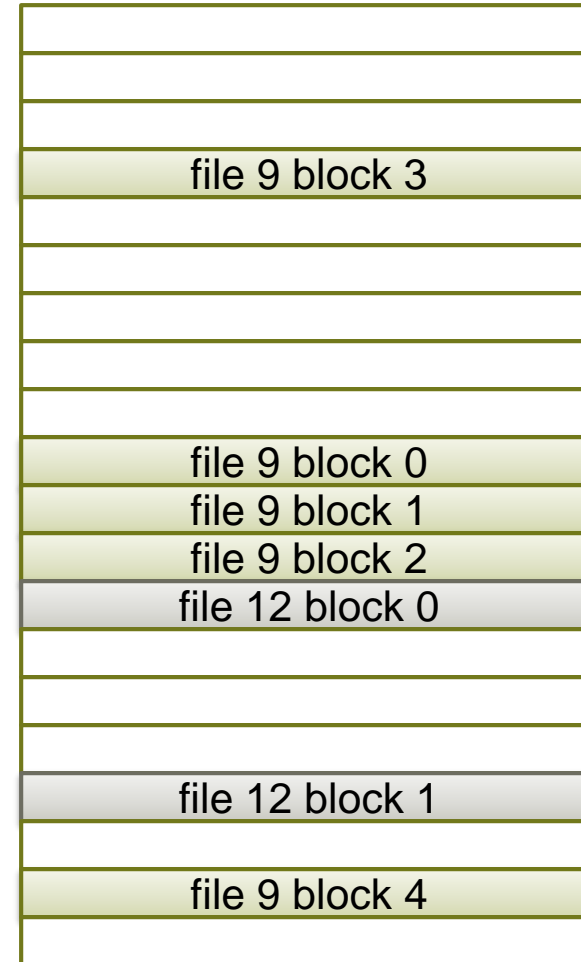

FAT file system

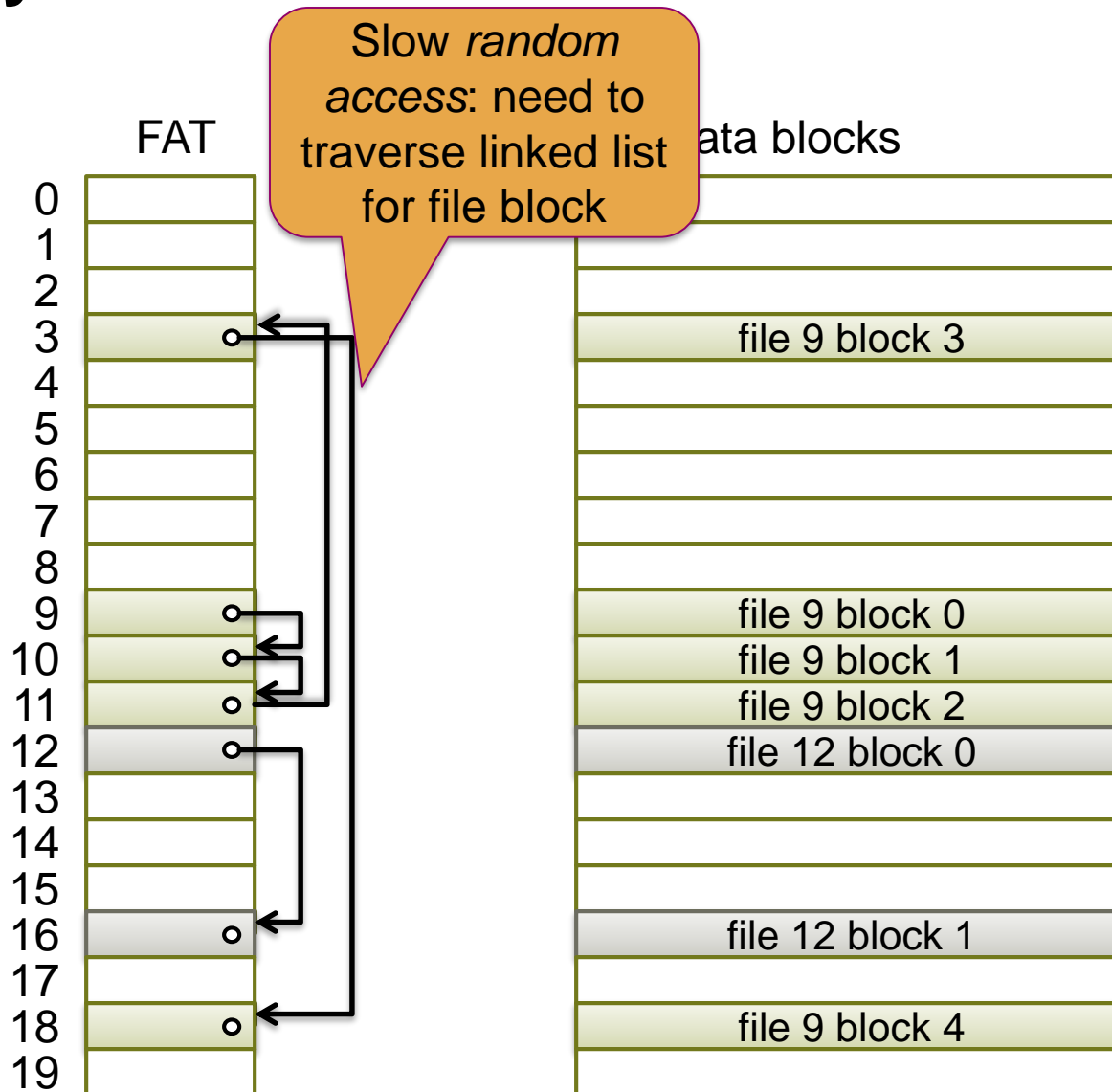

FAT file system

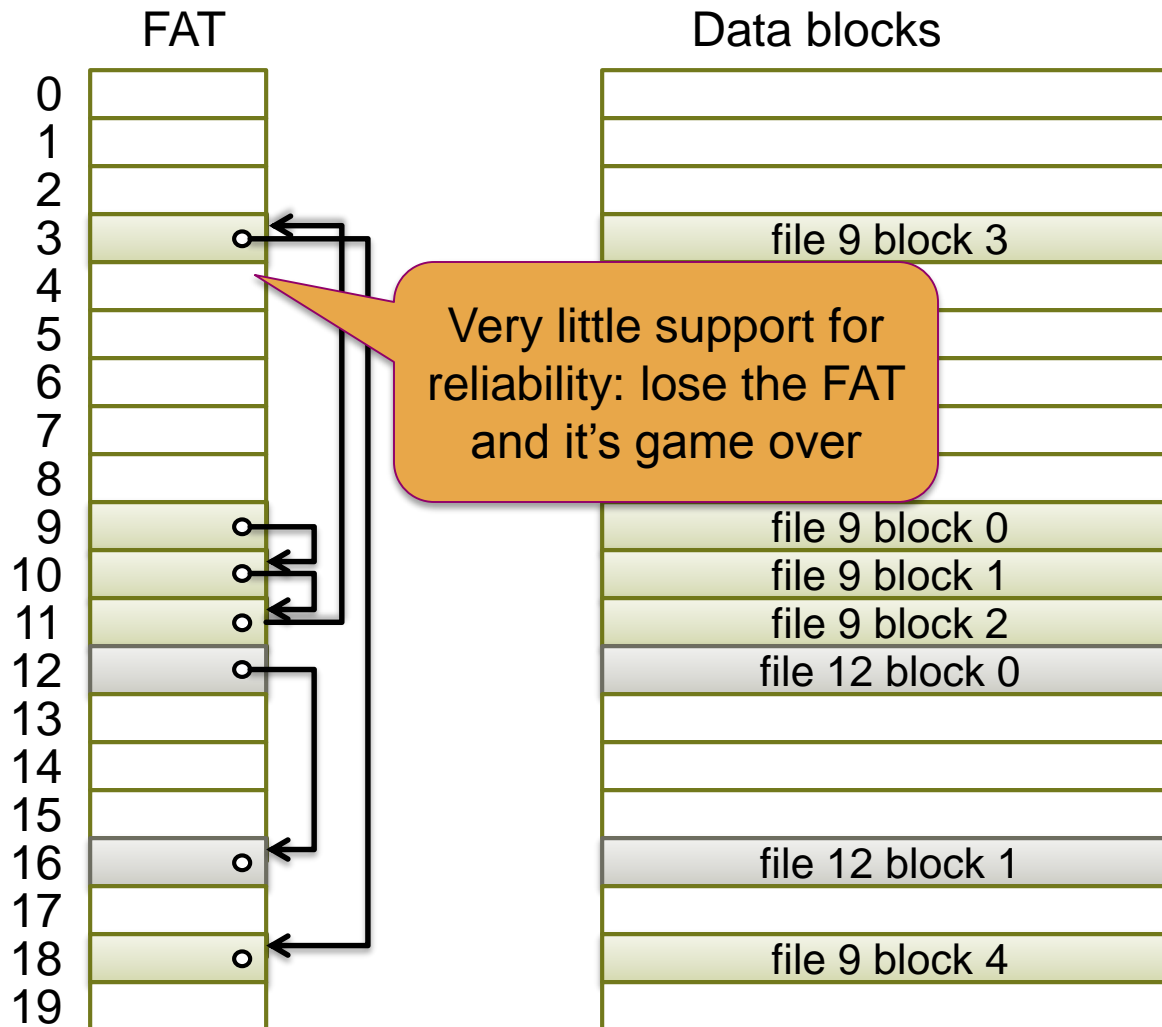

FAT file system

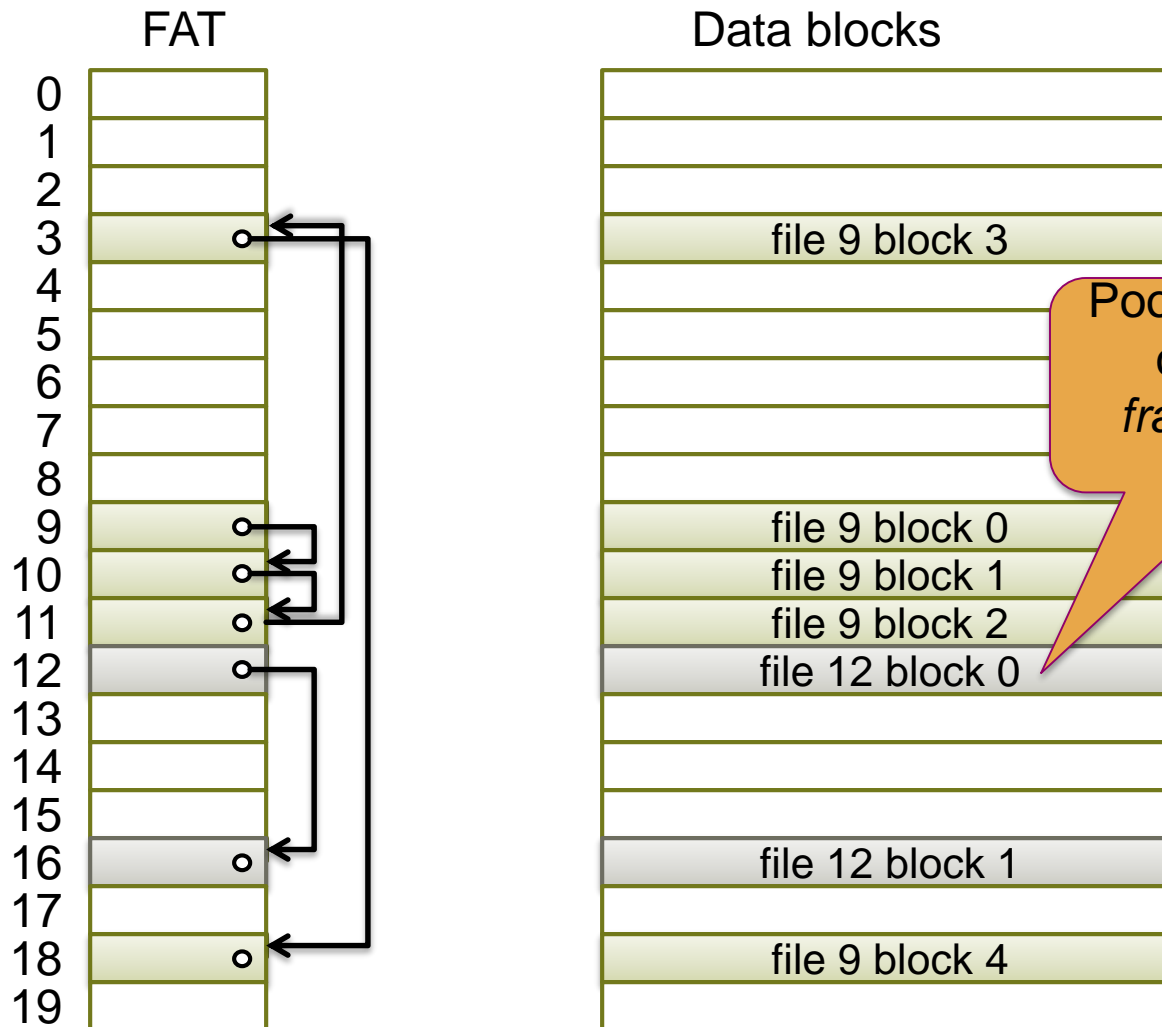

Poor locality: files can end up fragmented on disk

FFS

Unix Fast File System (FFS)

- First appeared in BSD in the mid 1980's
- Based on original Unix FS, with performance optimizations
- Basis for Linux ext{2,3} file systems

- **Recommended watching:**
 - Marshall Kirk McKusick "A Brief History of the BSD Fast Filesystem"
Keynote at USENIX FAST'15
(<https://www.youtube.com/watch?v=TMjgShRuYbg>)

FFS uses indexed allocation

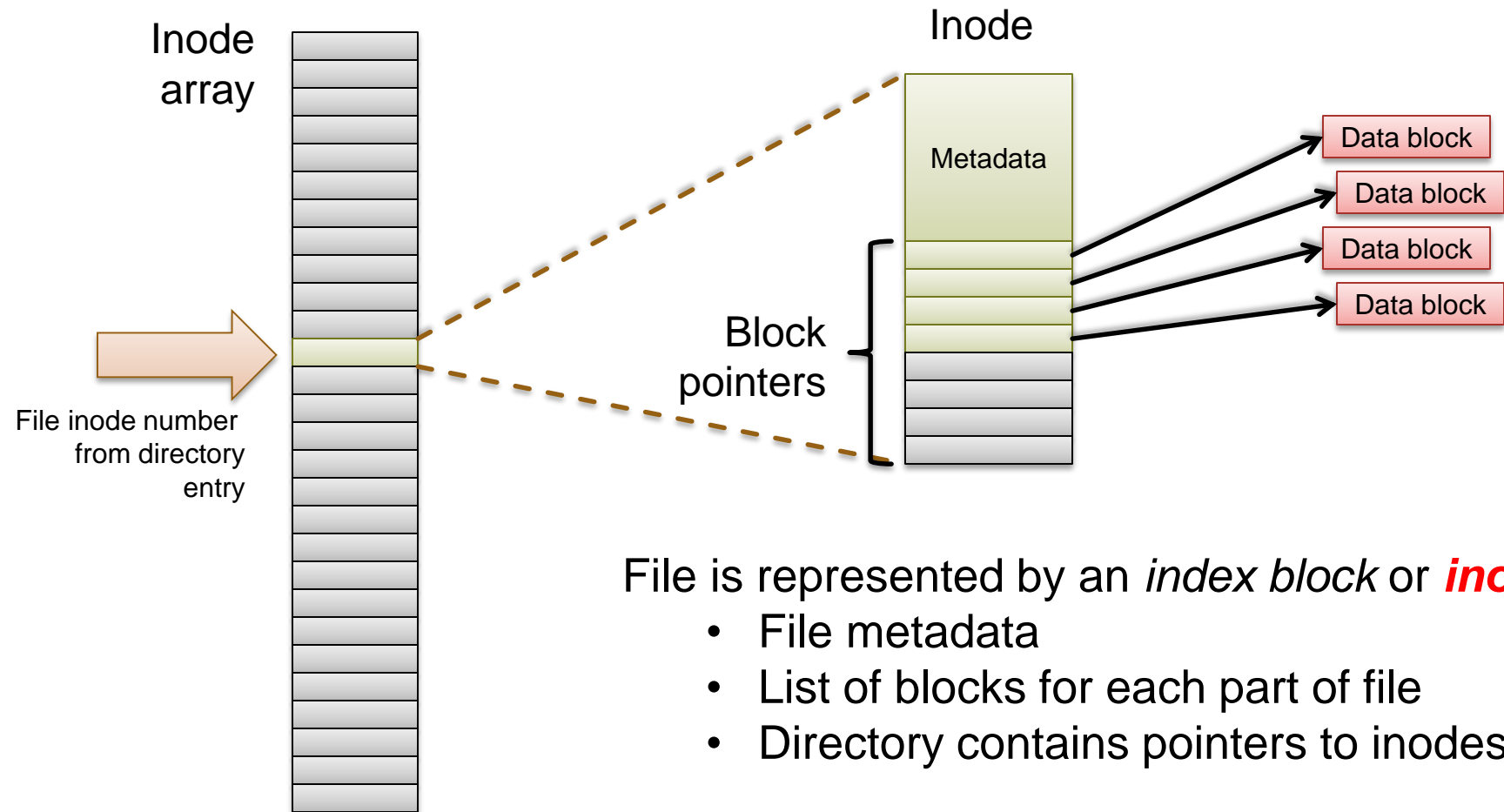

File is represented by an *index block* or **inode**

- File metadata
- List of blocks for each part of file
- Directory contains pointers to inodes

Inode and file size in FFS

- **Example:**
 - Inode is 1 block = 4,096 bytes
 - Block addresses = 8 bytes
 - Inode metadata = 512 bytes
- **Hence:**
 - $(4,096 - 512) / 8 = 448$ block pointers
 - $448 * 4,096 = 1,792$ kB max. file size

Unix file system inode format (simplified)

Inode:

(all blocks 4kB)

File mode
Owner/group
Timestamps
Size
<other metadata>

Unix file system inode format (simplified)

Inode:

(all blocks 4kB)

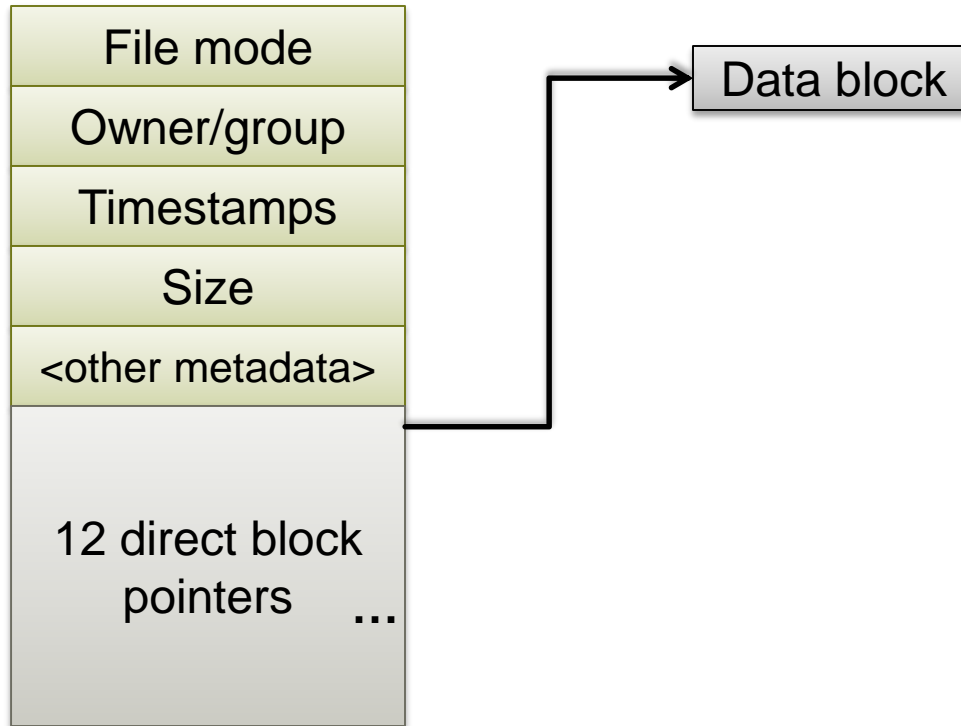

Unix file system inode format (simplified)

Inode:

(all blocks 4kB)

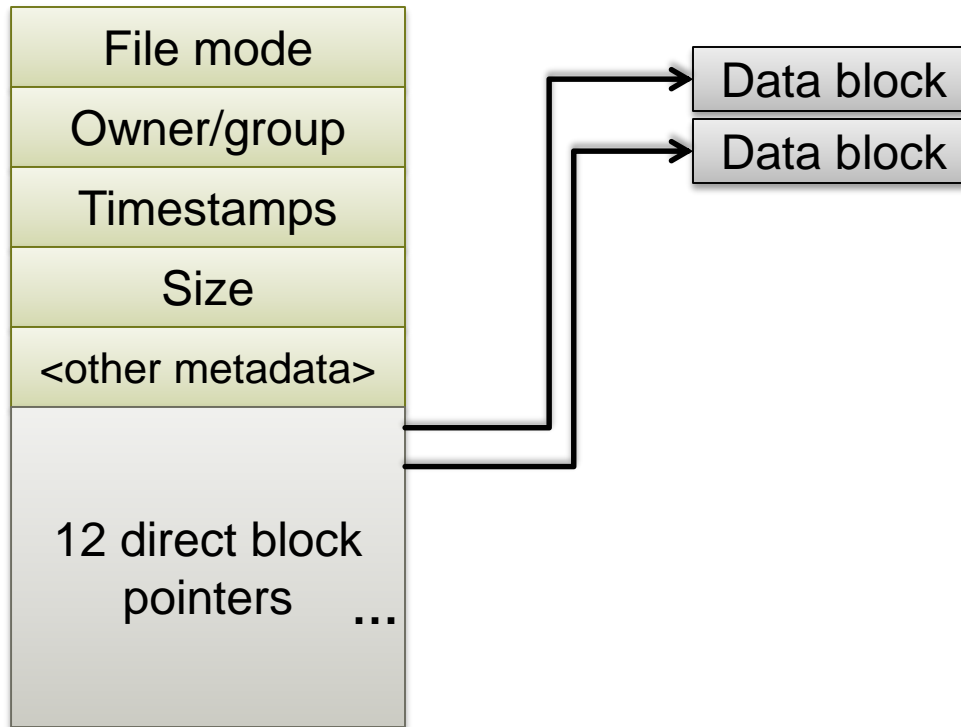

Unix file system inode format (simplified)

Inode:

(all blocks 4kB)

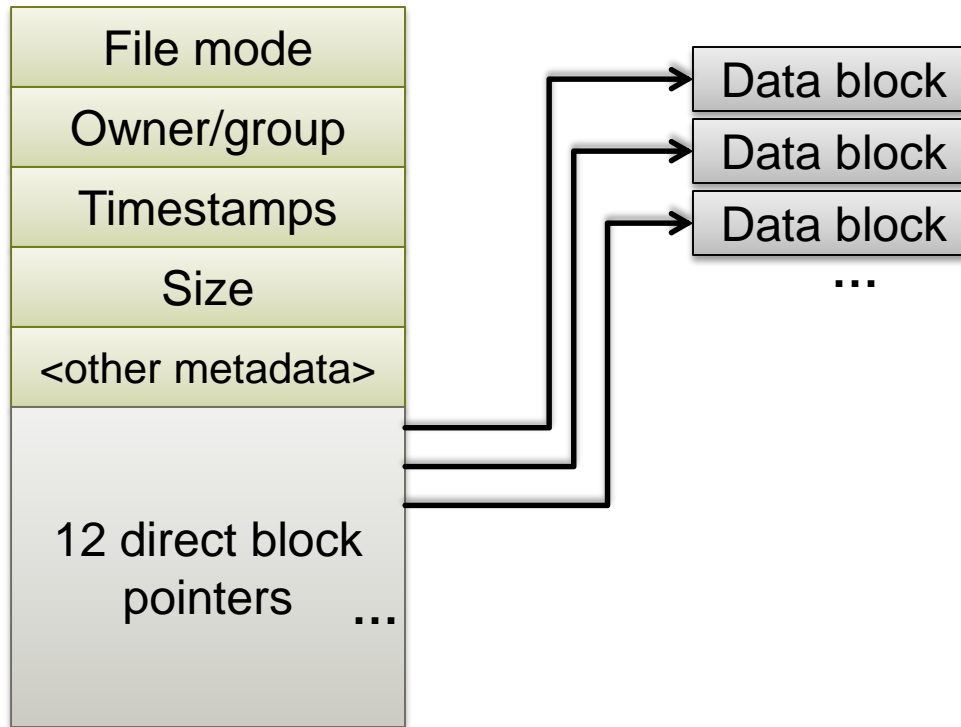

Unix file system inode format (simplified)

Inode:

(all blocks 4kB)

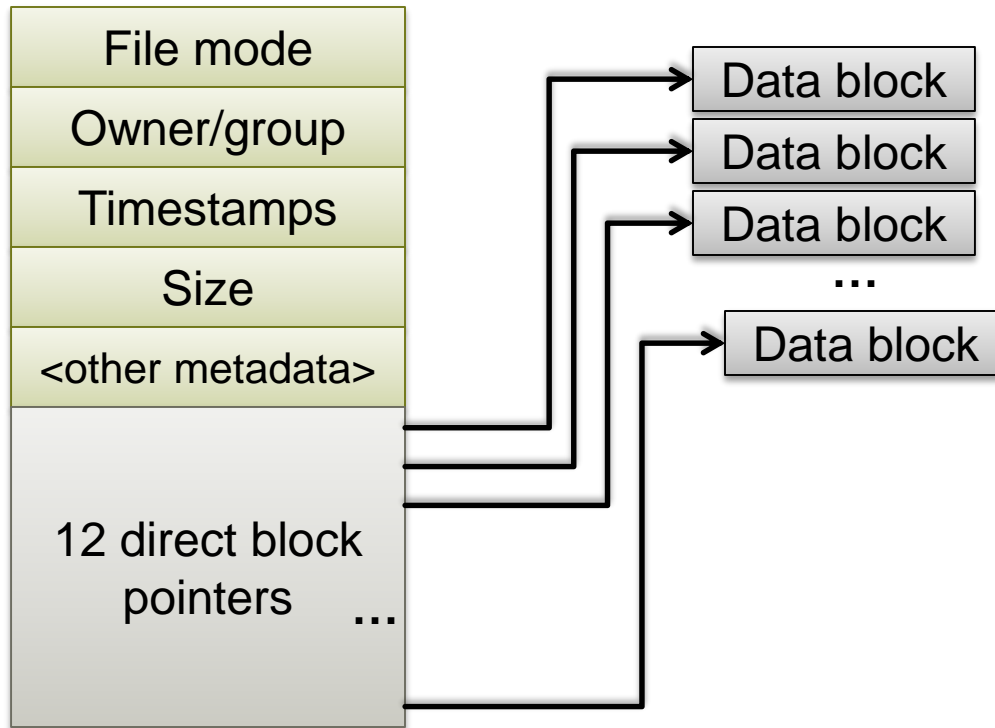

Unix file system inode format (simplified)

Inode:

(all blocks 4kB)

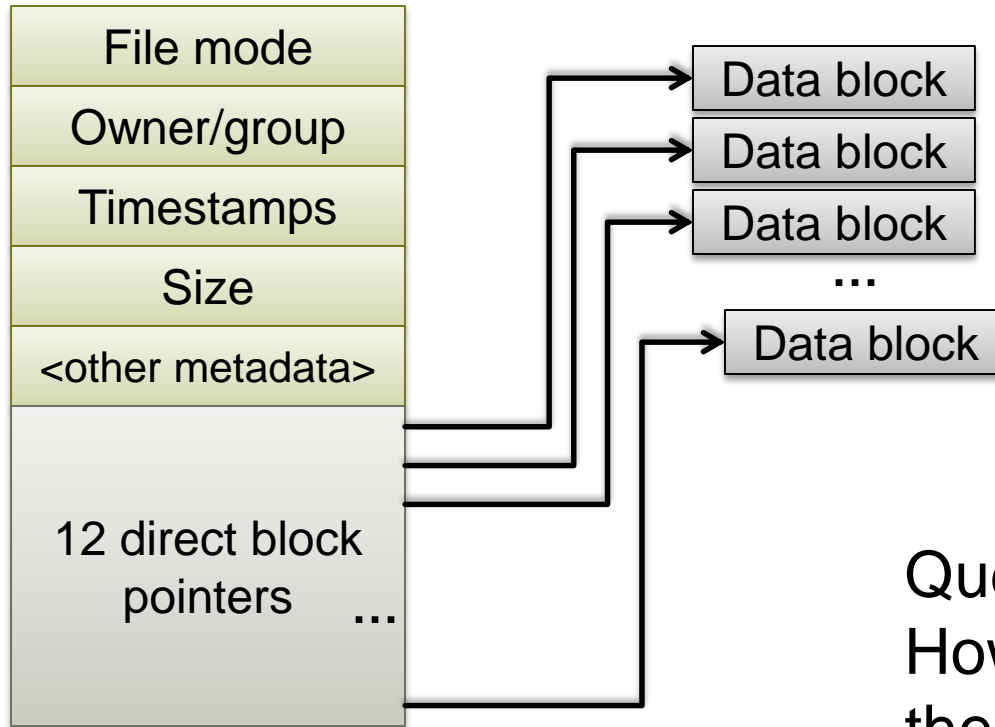

Question:

How to extend file size if there are no more block pointers in the Inode?

Unix file system inode format (simplified)

Inode:

(all blocks 4kB)

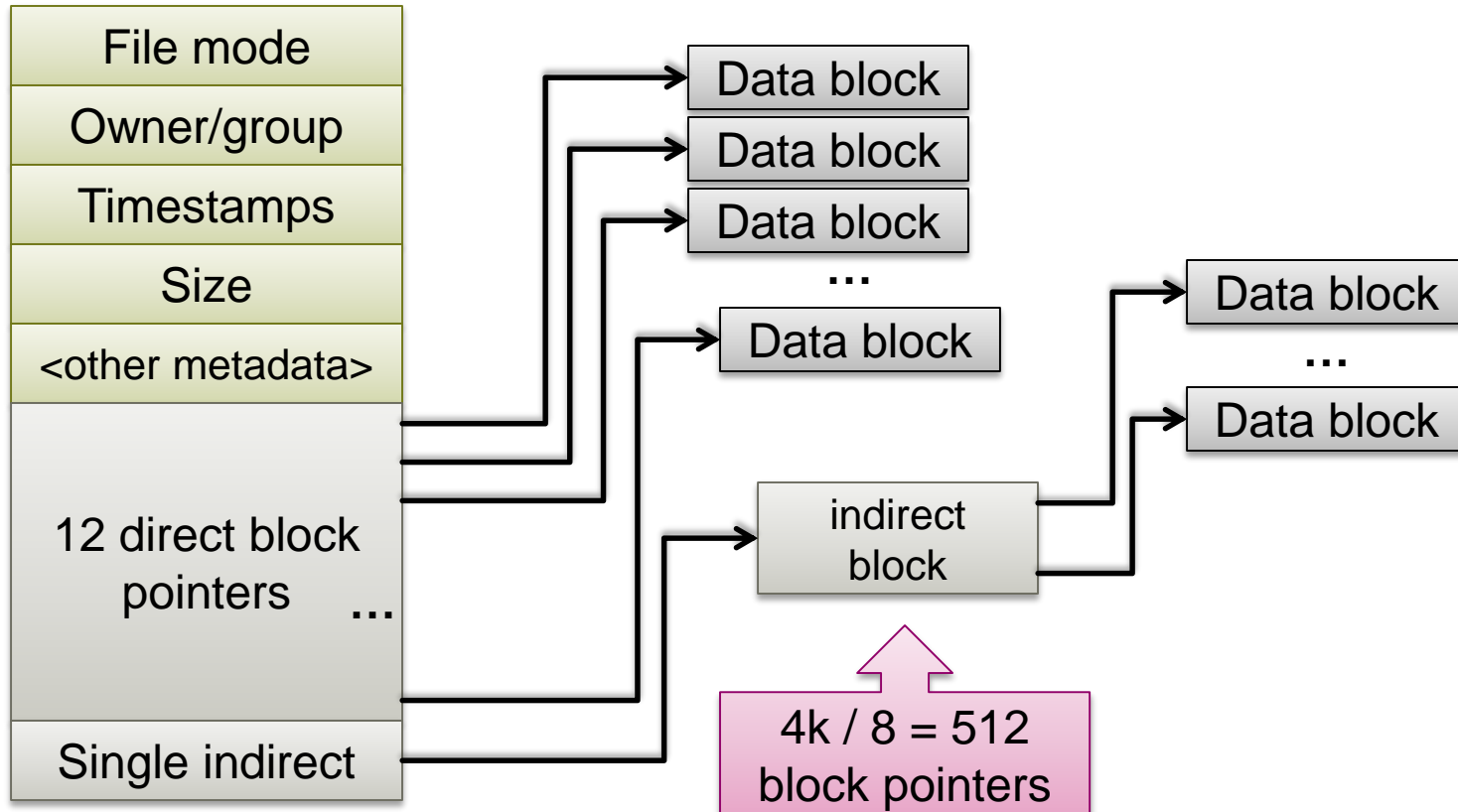

Unix file system inode format (simplified)

Inode:

(all blocks 4kB)

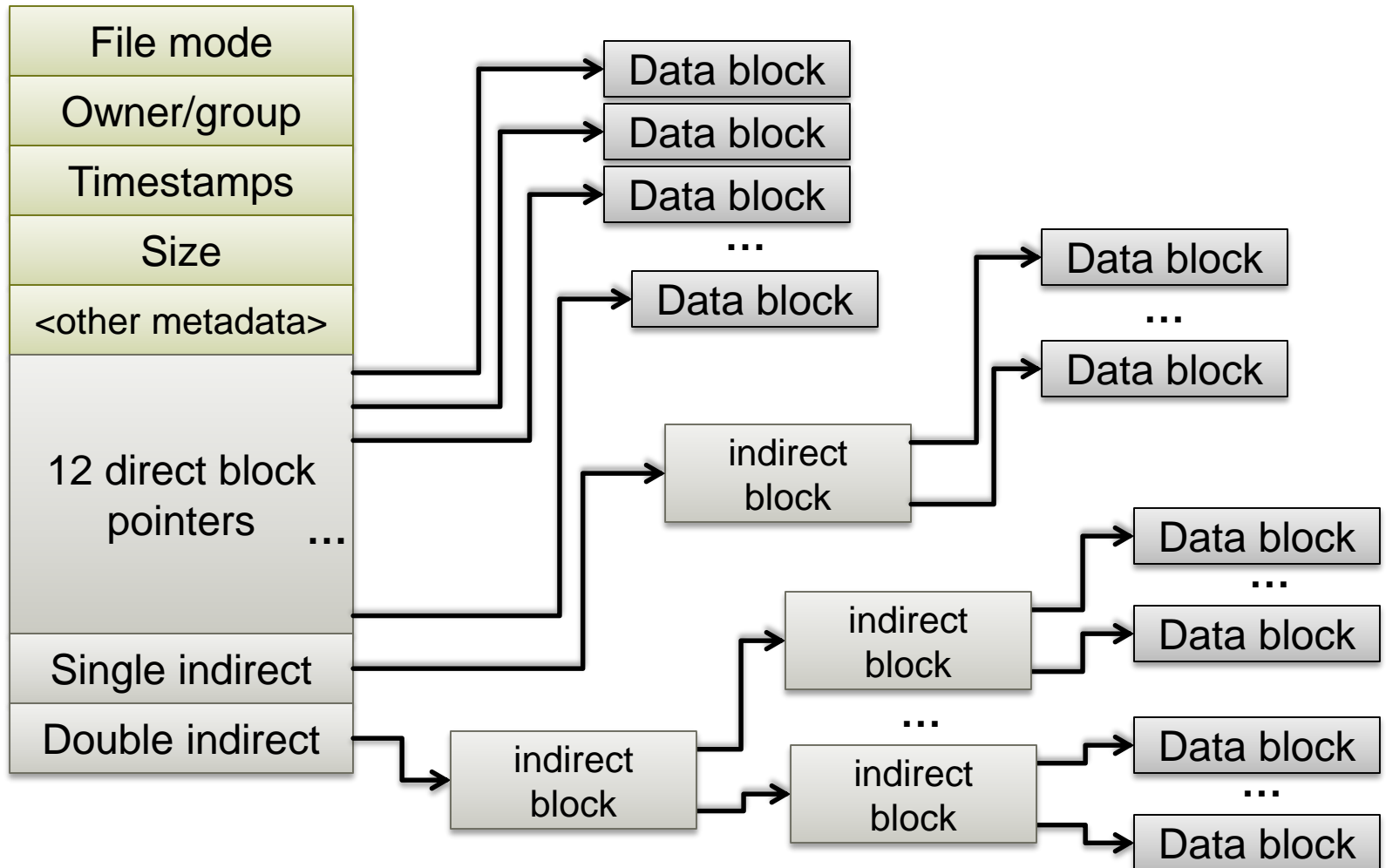

Unix file system inode format (simplified)

Inode:

(all blocks 4kB)

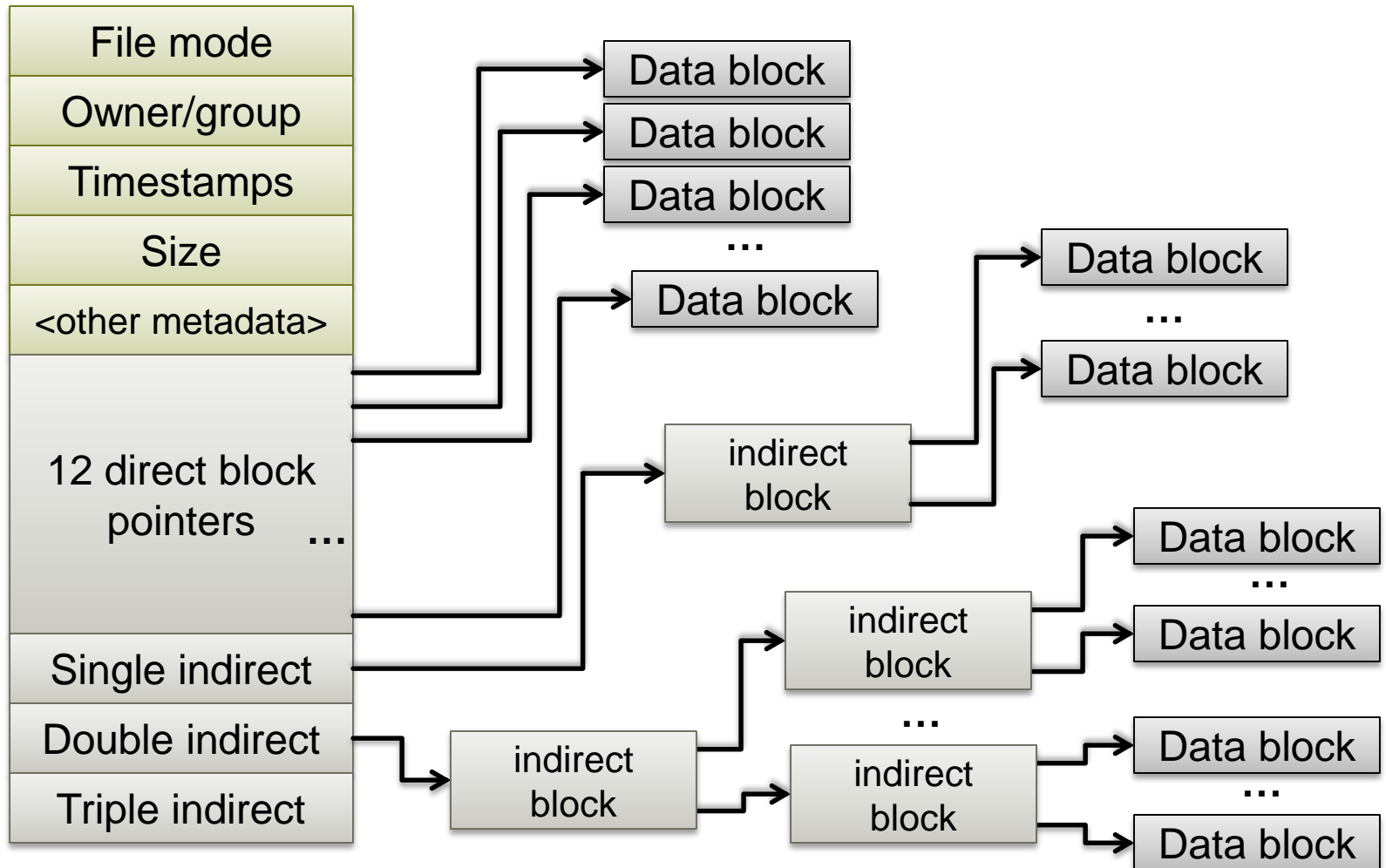

Unix file system inode format (simplified)

Inode:

(all blocks 4kB)

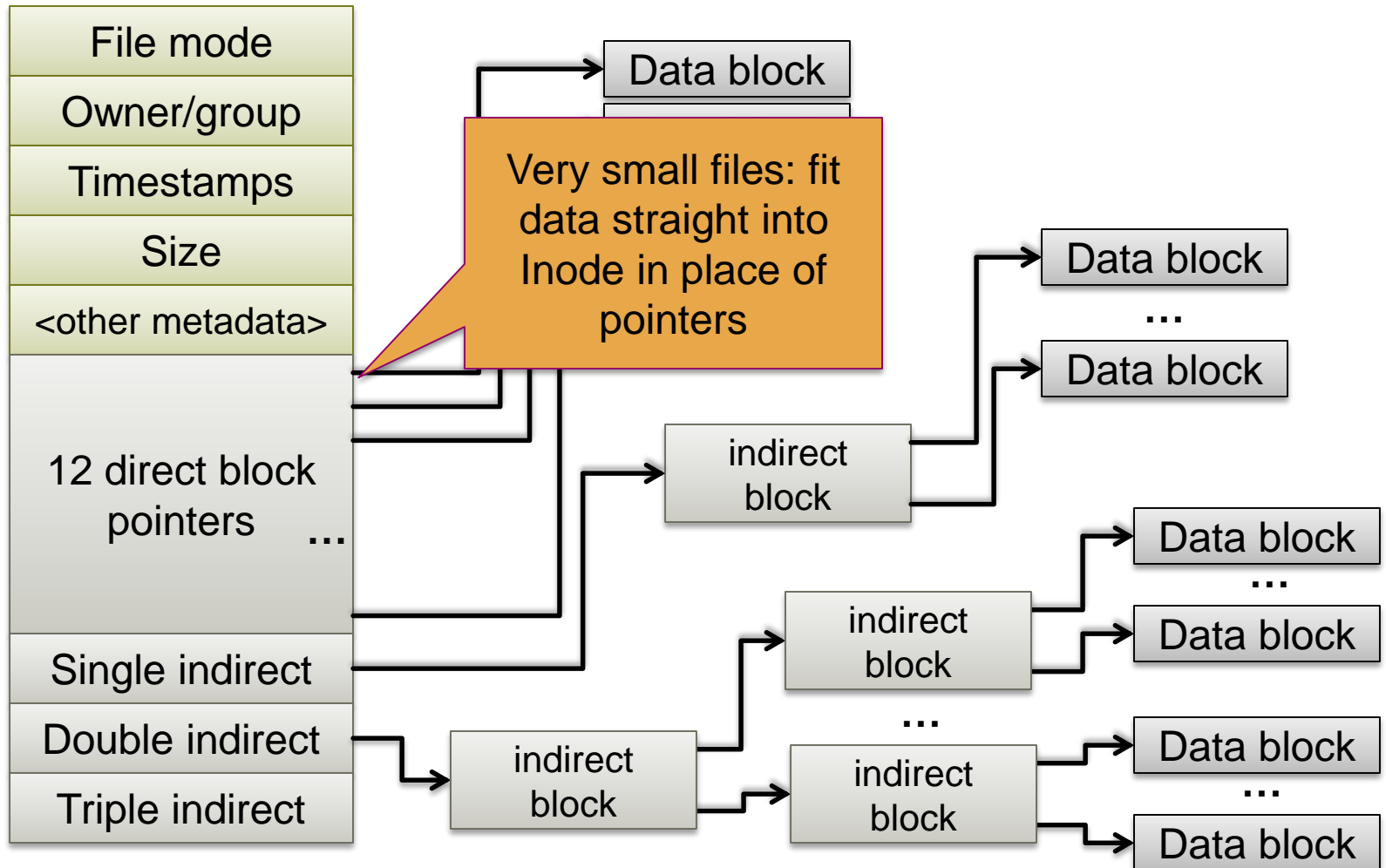

Unix file system inode format (simplified)

Inode:

(all blocks 4kB)

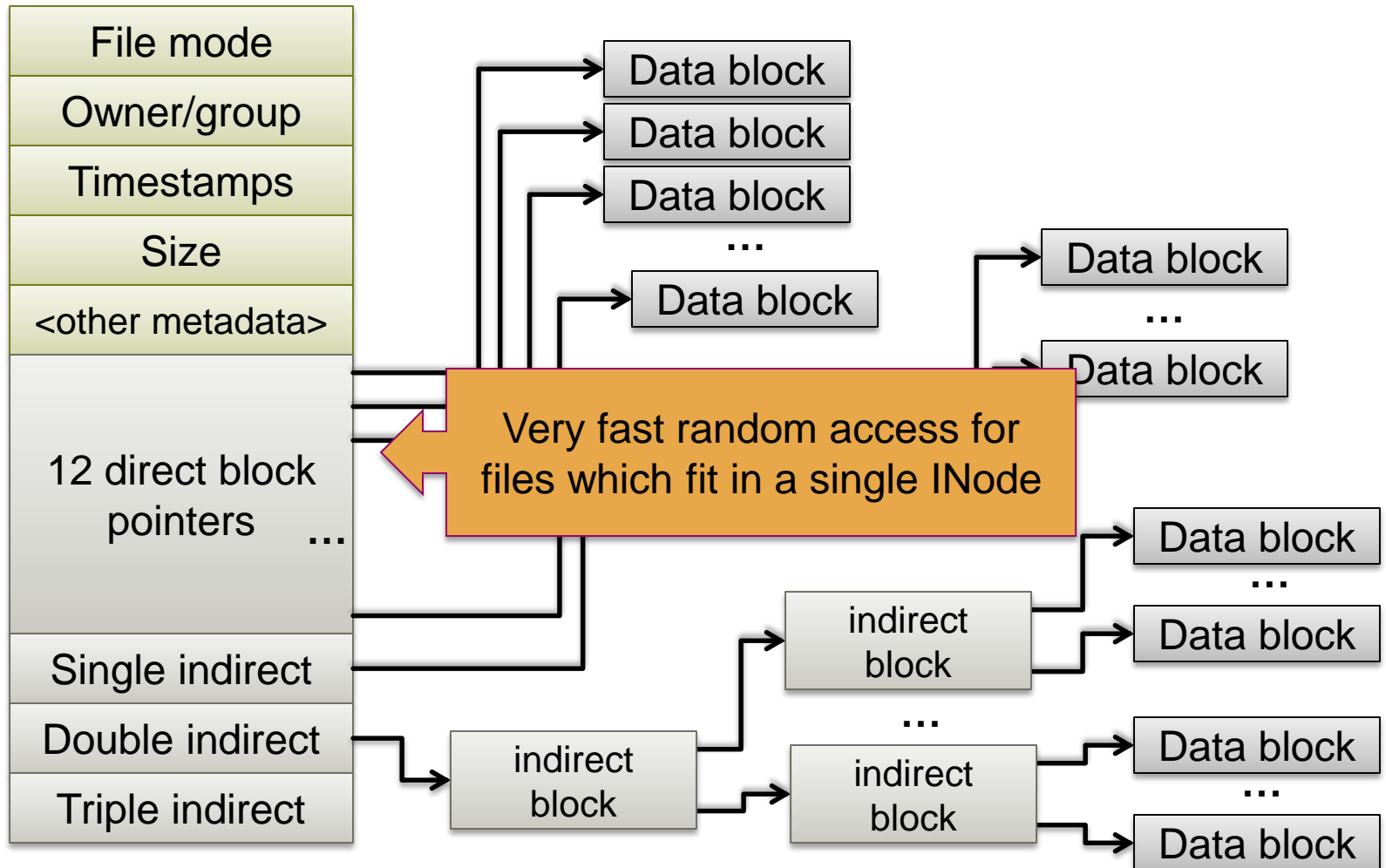

Unix file system inode format (simplified)

Inode:

(all blocks 4kB)

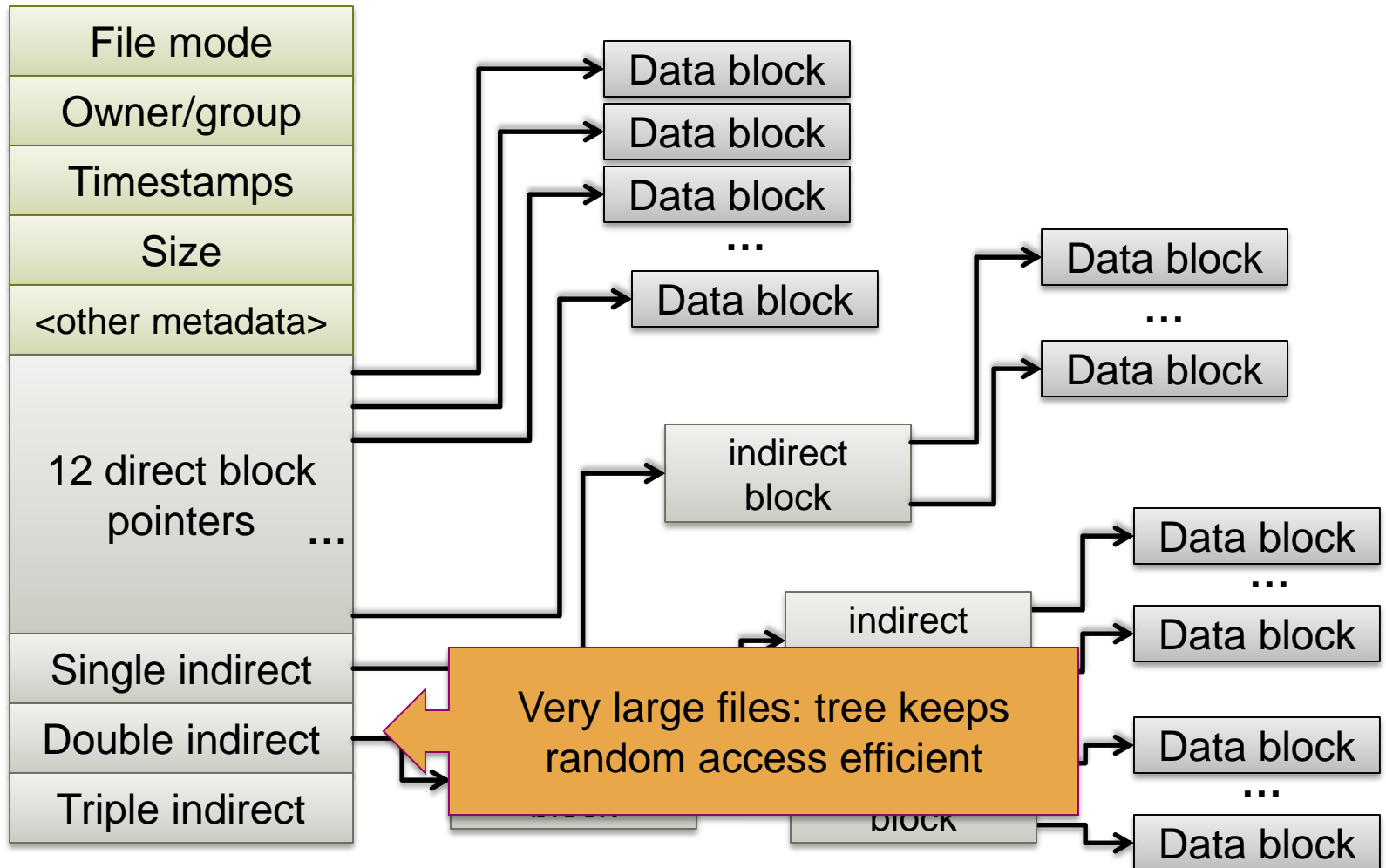

Free space map

- **FFS uses a simple bitmap**
 - Initialized when the file system is created
 - One bit per disk (file system) block
- **Allocation is reasonably fast**
 - Scan through lots of bits at a time
 - Bitmap can be cached in memory

Block groups

1. Optimize disk performance by keeping together related:

- Files
- Metadata (inodes)
- Free space map
- Directories

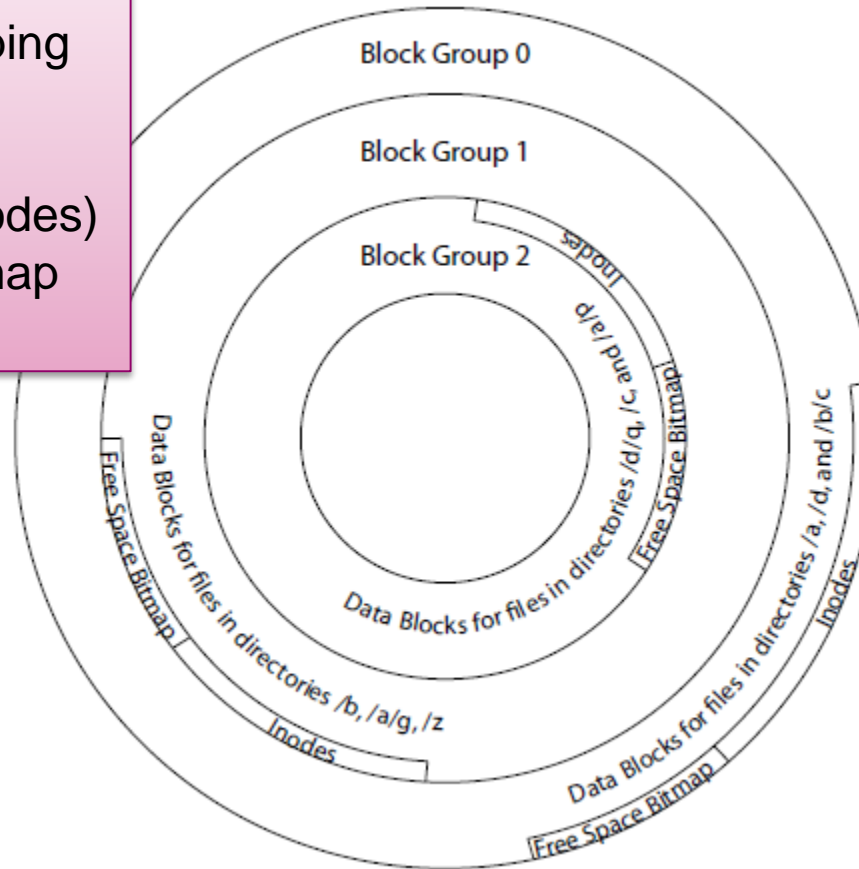

Block groups

2. Use *first-fit* allocation within a block group to improve disk locality

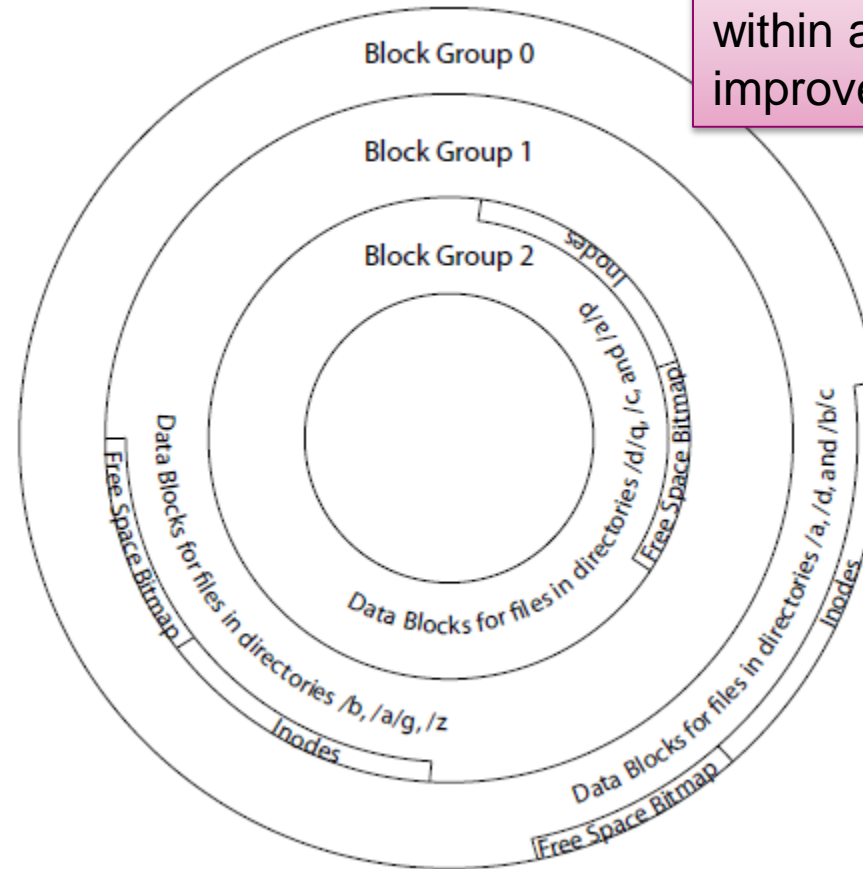

Block groups

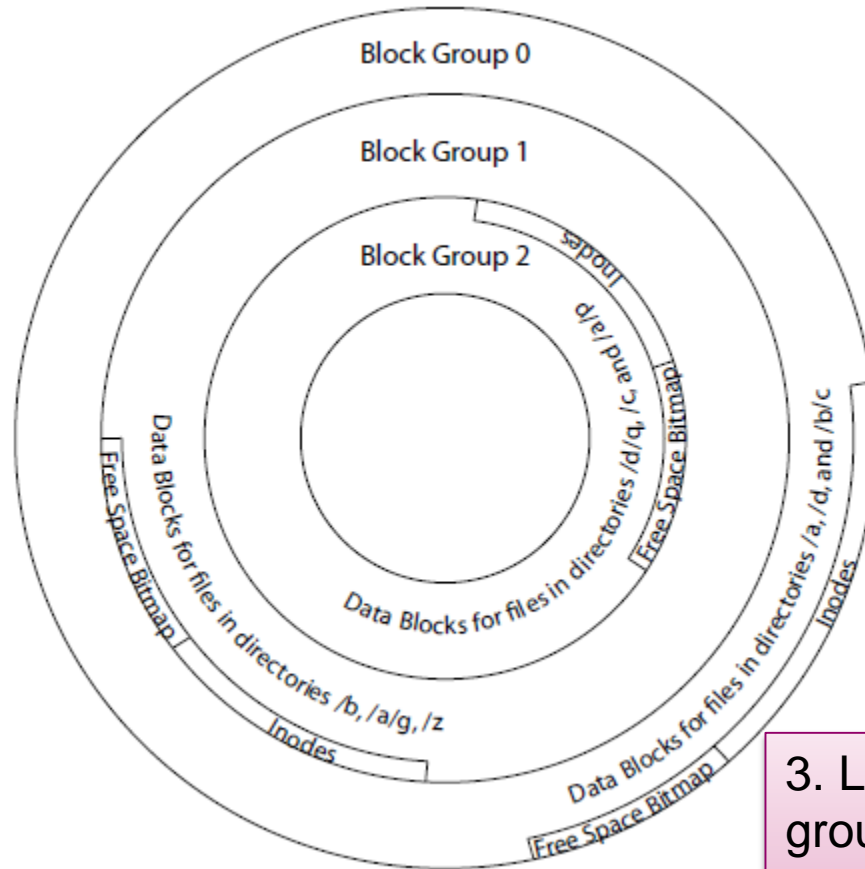

3. Layout and block groups defined in the *superblock* (not shown); Replicated several times.

NTFS

NTFS Master file table

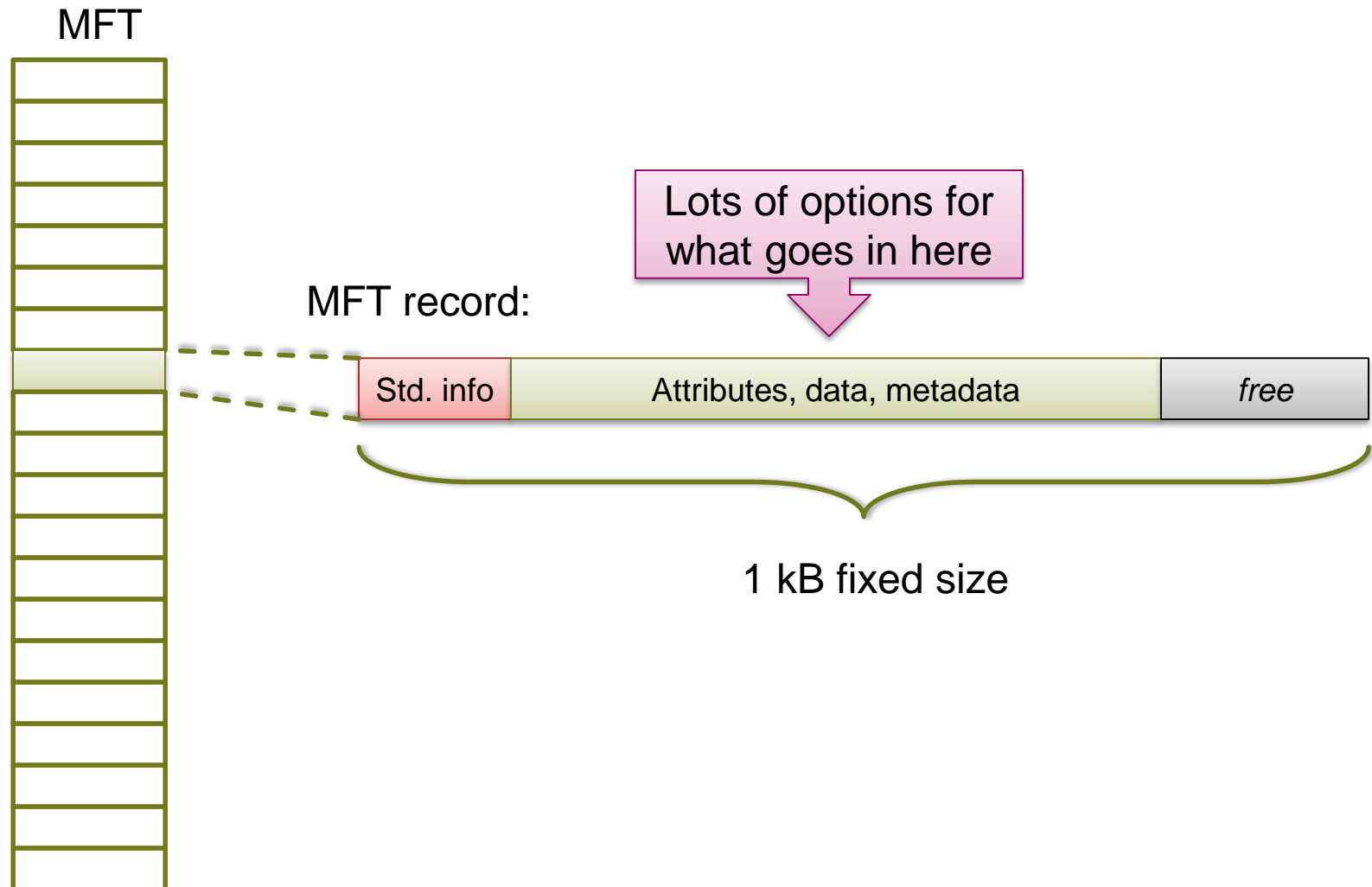

NTFS small files

- Small file fits into MFT record:

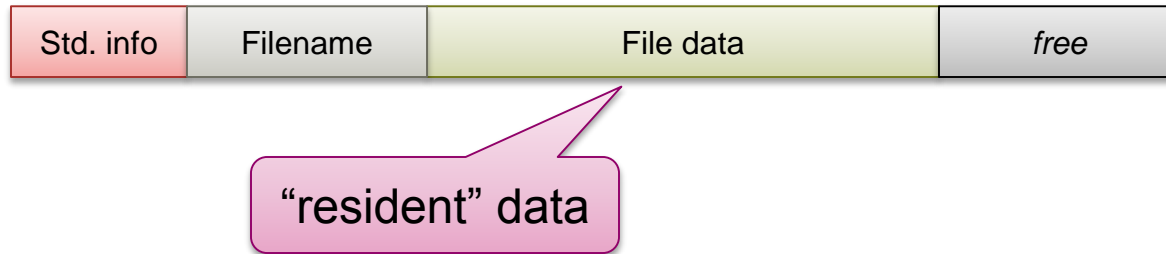

NTFS small files

- Small file fits into MFT record:

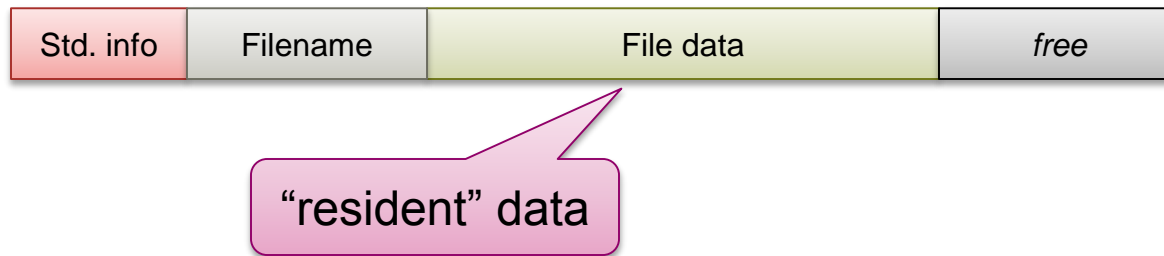

- Hard links (multiple names) stored in MFT:



NTFS normal files

- MFT holds list of *extents*:

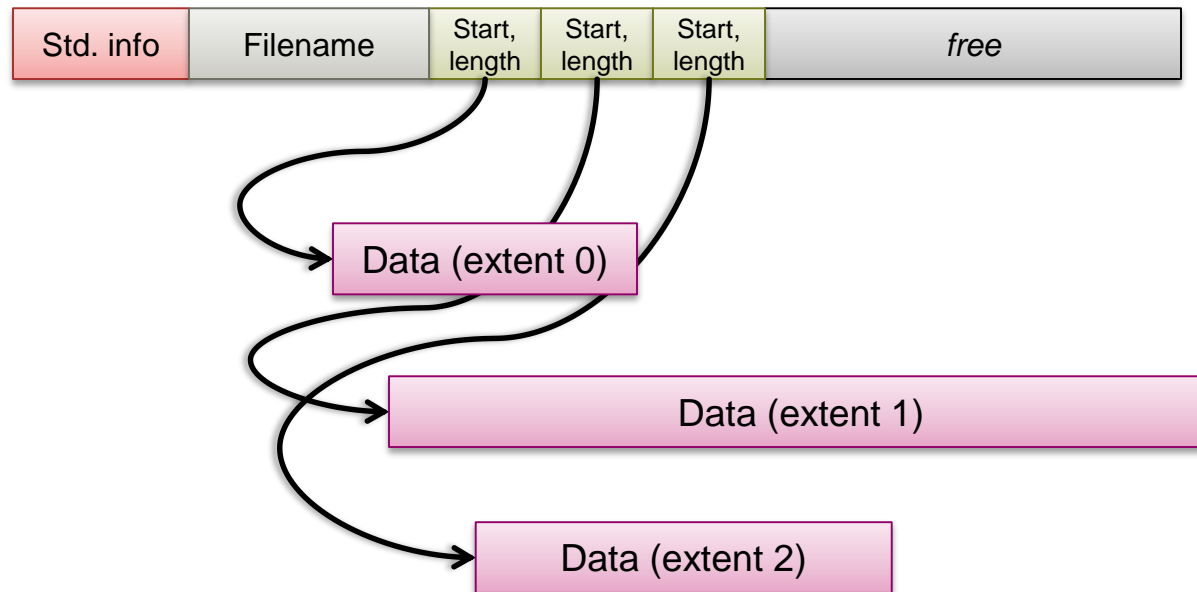

Too many attributes?

- Attribute list holds list of attribute locations

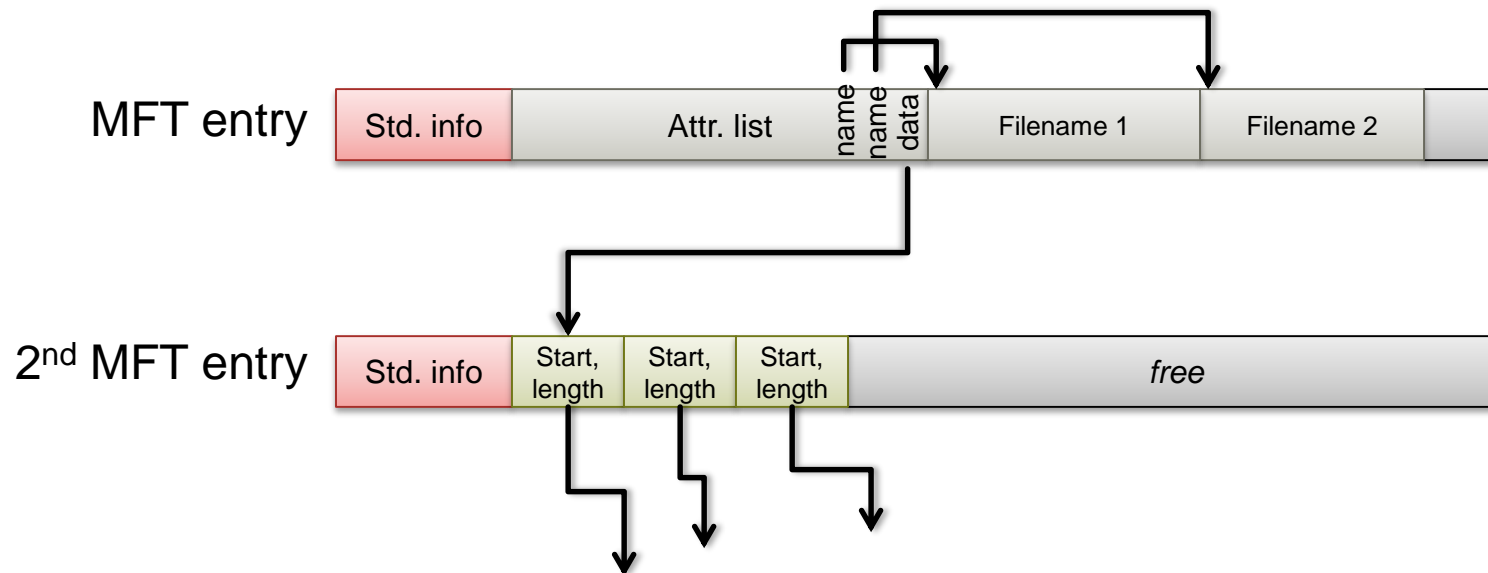

In addition, attributes can also be stored in extents \Rightarrow very large scaling (see book)

Metadata files

- File system metadata in NTFS is held *in files!*

File num.	Name	Description
0	\$MFT	Master file table
1	\$MFTirr	Copy of first 4 MFT entries
2	\$Logfile	Transaction log of FS changes
3	\$Volume	Volume information & metadata
4	\$AttrDef	Table mapping numeric IDs to attributes
5	.	Root directory
6	\$Bitmap	Free space bitmap
7	\$Boot	Volume boot record
8	\$BadClus	Bad cluster map
9	\$Secure	Access control list database
10	\$UpCase	Filename mappings to DOS
11	\$Extend	Extra file system attributes (e.g. quota)

Metadata files

- File system metadata in NTFS is held *in files!*

File num.	Name	Description
0	\$MFT	Master file table
1	\$MFTirr	Copy of first 4 MFT entries
2	\$Logfile	Transaction log of FS changes
3	\$Volume	Volume information & metadata
4	\$AttrDef	Table mapping numeric IDs to attributes
5	.	Root directory
6	\$Bitmap	Free space bitmap
7	\$Boot	Volume boot record
8	\$BadClus	Bad cluster map
9	\$Secure	Access control list database
10	\$UpCase	Filename mappings to DOS
11	\$Extend	Extra file system attributes (e.g. quota)

Metadata files

- File system metadata in NTFS is held *in files!*

File num.	Name	Description
0	\$MFT	Master file table
1	\$MFTirr	Copy of first 4 MFT entries
2	\$Logfile	Transaction log of FS changes
3	\$Volume	Volume information & metadata
4	\$AttrDef	Table mapping numeric IDs to attributes
5	.	Root directory
6	\$Bitmap	Free space bitmap
7	\$Boot	Volume boot record
8	\$BadClus	Bad cluster map
9	\$Secure	Access control list database
10	\$UpCase	Filename mappings to DOS
11	\$Extend	Extra file system attributes (e.g. quota)

Metadata files

- File system metadata in NTFS is held *in files!*

File num.	Name	Description
0	\$MFT	Master file table
1	\$MFTirr	Copy of first 4 MFT entries
2	\$Logfile	Transaction log of FS changes
3	\$Volume	Volume information & metadata
4	\$AttrDef	Table mapping numeric IDs to attributes
5	.	Root directory
6	\$Bitmap	Free space bitmap
7	\$Boot	Volume boot record
8	\$BadClus	Bad cluster map
9	\$Secure	Access control list database
10	\$UpCase	Filename mappings to DOS
11	\$Extend	Extra file system attributes (e.g. quota)

Metadata files

- File system metadata in NTFS is held *in files!*

File num.	Name	Description
0	\$MFT	Master file table
1	\$MFTirr	Copy of first 4 MFT entries
2	\$Logfile	Transaction log of FS changes
3	\$Volume	Volume information & metadata
4	\$AttrDef	Table mapping numeric IDs to attributes
5	.	Root directory
6	\$Bitmap	Free space bitmap
7	\$Boot	Volume boot record
8	\$BadClus	Bad cluster map
9	\$Secure	Access control list database
10	\$UpCase	Filename mappings to DOS
11	\$Extend	Extra file system attributes (e.g. quota)

Metadata files

- File system metadata in NTFS is held *in files!*

File num.	Name	Description
0	\$MFT	Master file table
1	\$MFTirr	Copy of first 4 MFT entries
2	\$Logfile	Transaction log of FS changes
3	\$Volume	Volume information & metadata
4	\$AttrDef	Table mapping numeric IDs to attributes
5	.	Root directory
6	\$Bitmap	Free space bitmap
7	\$Boot	Volume boot record
8	\$BadClus	Bad cluster map
9	\$Secure	Access control list database
10	\$UpCase	Filename mappings to DOS
11	\$Extend	Extra file system attributes (e.g. quota)

Question:

Huh?

Where is it then?

Answer:

First sector of volume points to first block of MFT

In-memory Data Structures

Opening a file

- Directories translated into kernel data structures on demand:

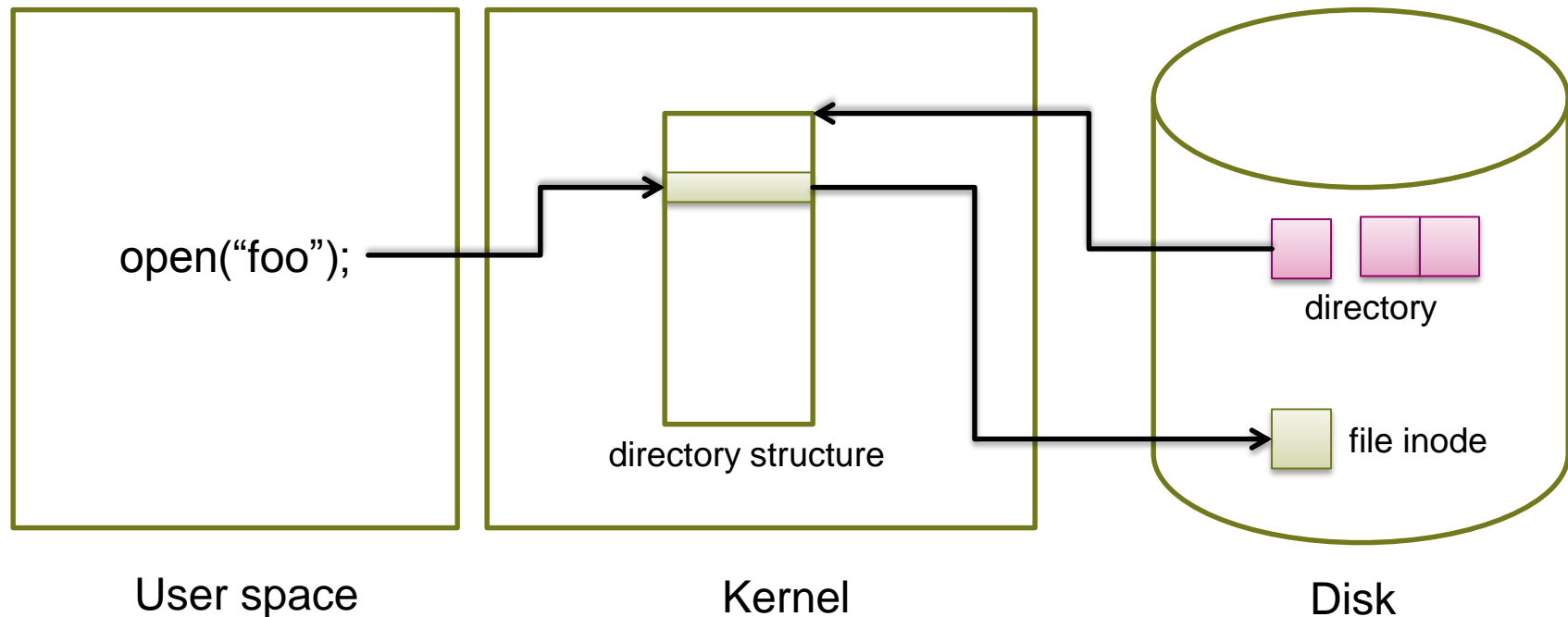

Reading and writing

- Per-process open file table → index into...
- System open file table → cache of inodes

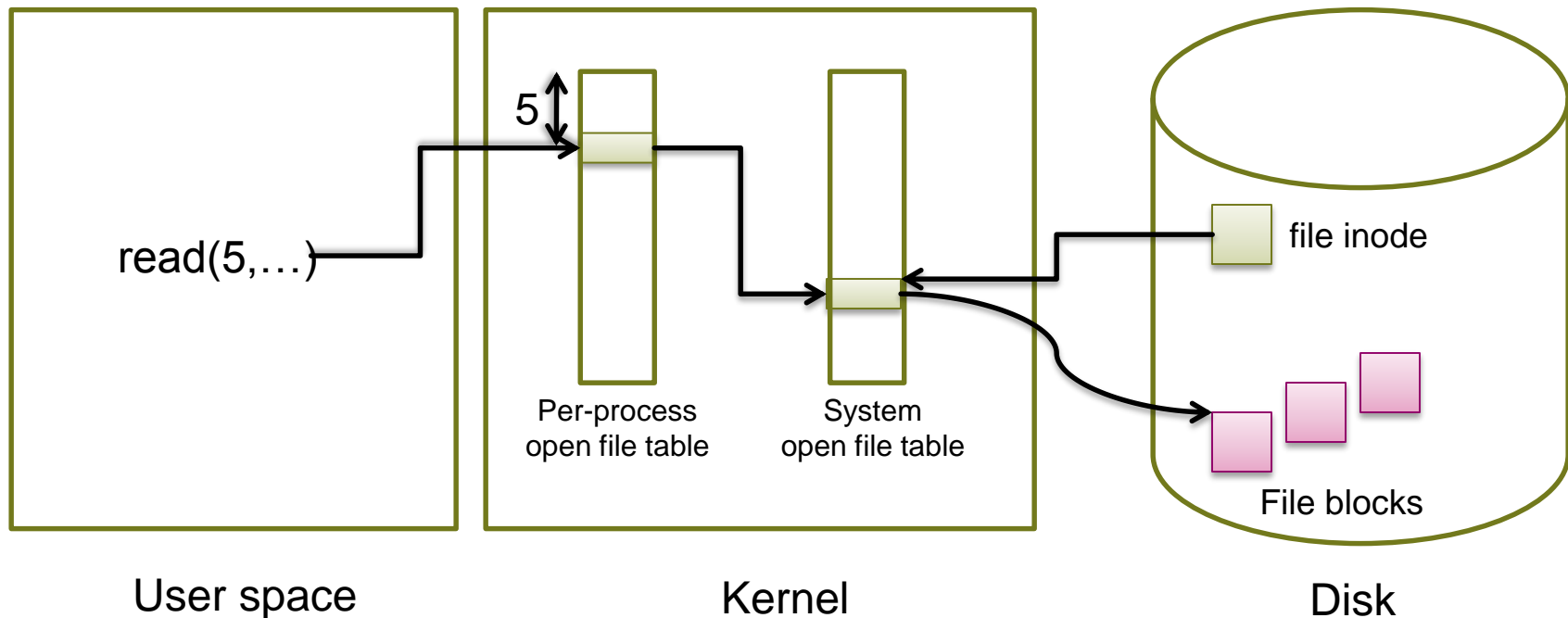

Efficiency and Performance

- **Efficiency dependent on:**
 - disk allocation and directory algorithms
 - types of data kept in file's directory entry
- **Performance**
 - disk cache – separate section of main memory for frequently used blocks
 - free-behind and read-ahead – techniques to optimize sequential access
 - improve PC performance by dedicating section of memory as virtual disk, or RAM disk

Page cache

- A page cache caches pages rather than disk blocks using virtual memory techniques
- Memory-mapped I/O uses a page cache
- Routine I/O through the file system uses the buffer (disk) cache
- This leads to the following figure

Two layers of caching?

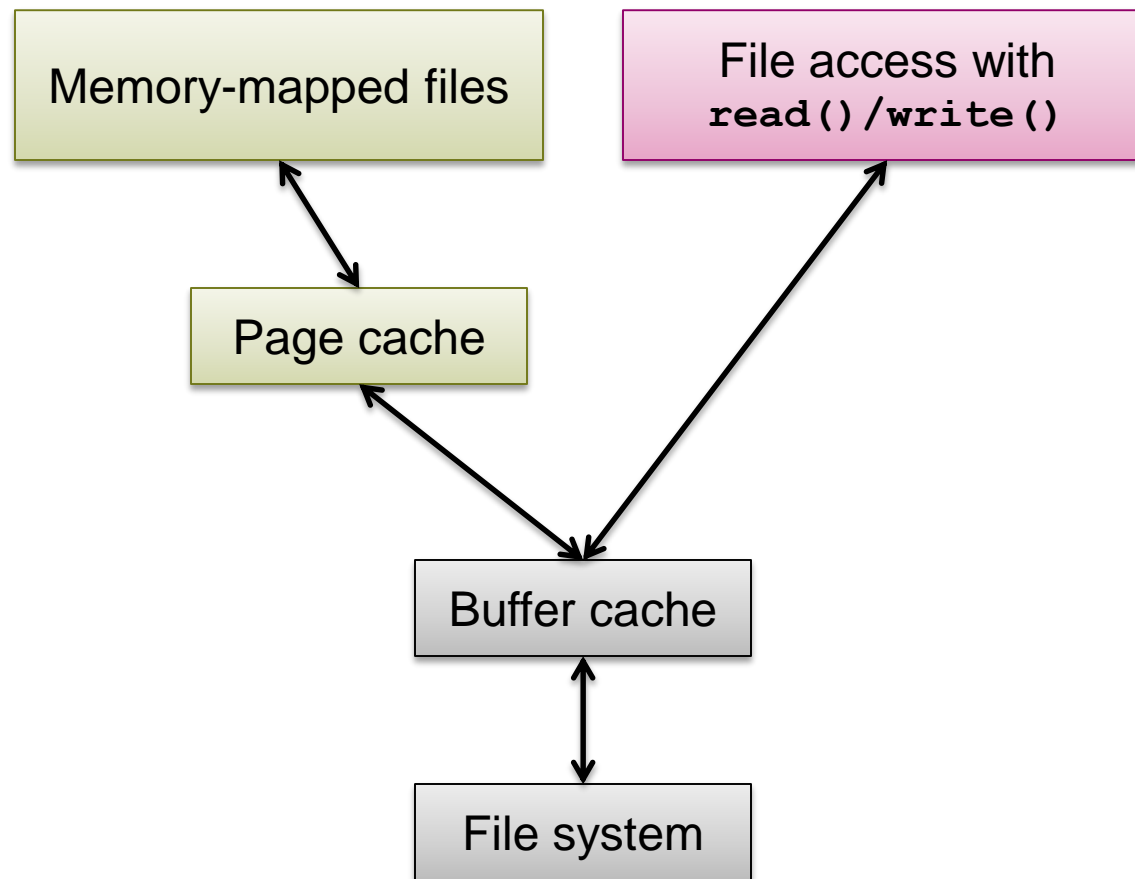

Unified buffer cache

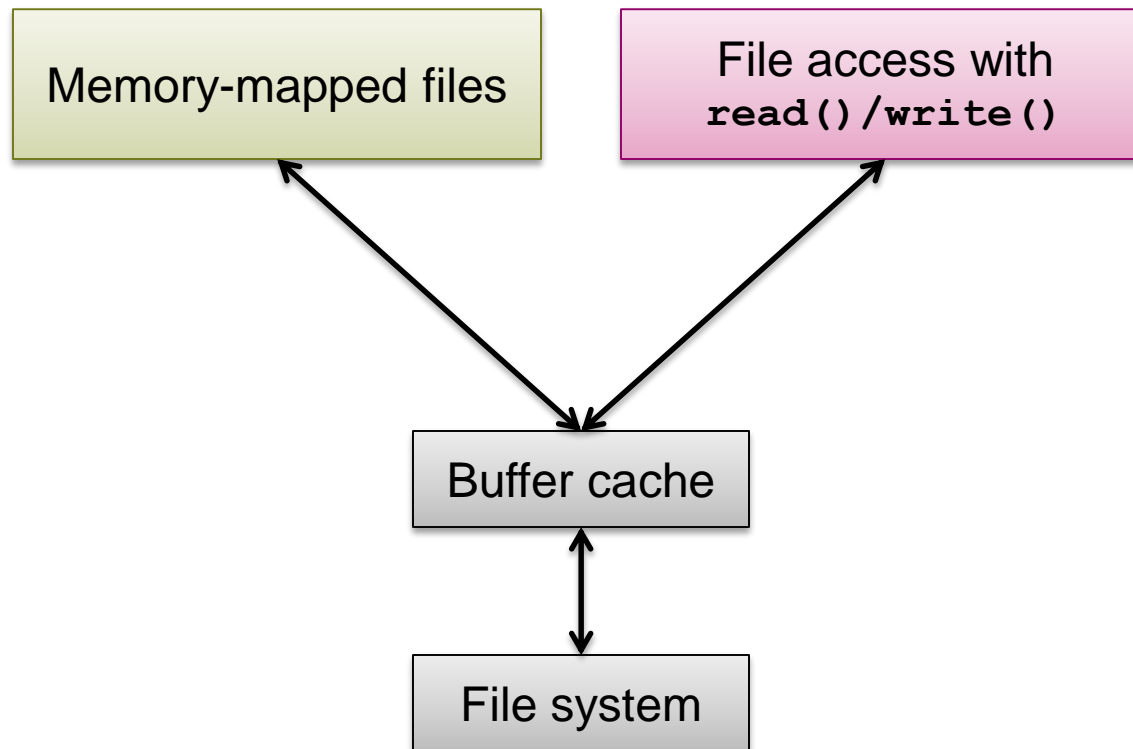

Concurrency

Concurrency

- 1. Must ensure that, regardless of concurrent access, file system *integrity* is ensured**
 - Careful design of file system structures
 - Internal locking in the file system
 - Ordering of writes to disk to provide transactions

- 2. Provide mechanisms for users to avoid conflicts themselves**
 - Advisory locks
 - Mandatory locks

Common locking facilities

- **Type:**
 - Advisory: separate locking facility
 - Mandatory: write/read operations will fail

- **Granularity:**
 - Whole-file
 - Byte ranges (or record ranges)
 - Write-protecting executing binaries

Compare with databases

- **Databases have way better notions of:**
 - Locking between concurrent users
 - Durability in the event of crashes
- **Records and indexed files have largely disappeared in favor of databases**
- **File systems remain much easier to use**
 - And much, much faster
 - As long as it doesn't matter...

Recovery

- **Consistency checking – compares data in directory structure with data blocks on disk, and tries to fix inconsistencies**
- **Use system programs to back up data from disk to another storage device (floppy disk, magnetic tape, other magnetic disk, optical)**
- **Recover lost file or disk by restoring data from backup**